

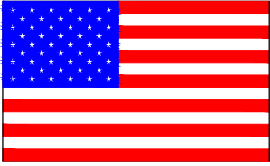

Woodbine, Iowa



Made in America

OWNER'S / OPERATOR'S MANUAL

- Safety Information
- Warranty Information
- Operator's Instructions
- Maintenance Instructions
- Parts List

Original Series 500-1600 LB Capacity

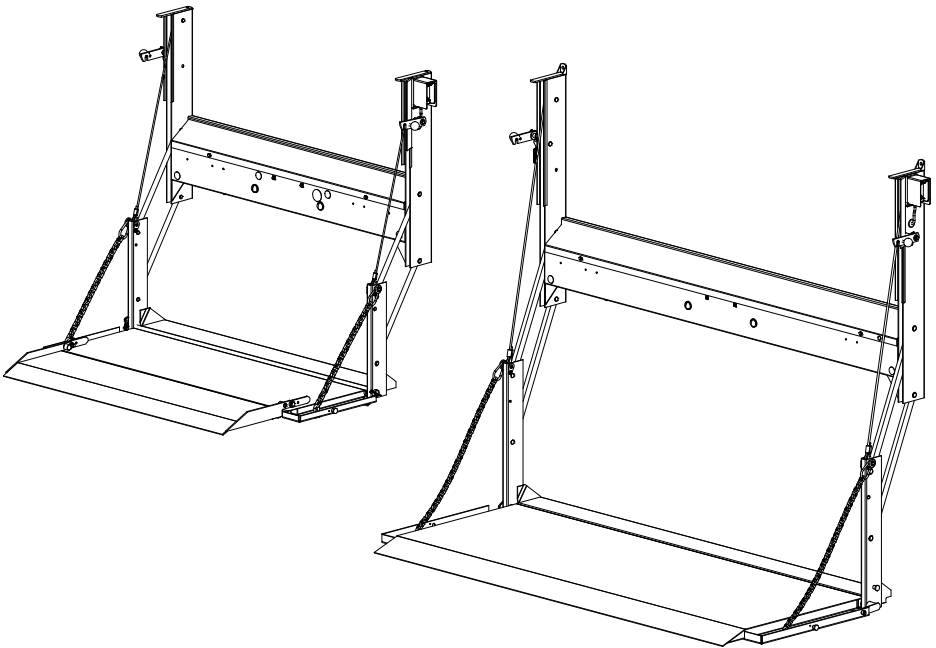

Before installing or using this Liftgate, please observe the Vehicle Loading Limitations. These loading limitations are outlined in the Vehicle Owner's Manual and the Safety Compliance Certification Label located on the driver's door pillar.



PLEASE KEEP IN VEHICLE



TABLE OF CONTENTS

	<u>Page#</u>
<u>Introduction</u>	
To the Owner\Operator.	3
<u>Safety Decals</u>	
Location and Descriptions.	4 - 5
Decal Replacement.	5
<u>Operator's Instructions</u>	
Original Series Terms and Method of Operation.	6
Operator's Instructions.	7 - 8
Drop Away Feature.	9
<u>Electrical Wiring Diagrams</u>	
Standard Fixed Control.	10
Optional Pendant Control.	11
Power Unit Control Circuit.	12
<u>Maintenance and Service</u>	13
<u>Troubleshooting</u>	14
<u>Warranty</u>	
Standard Warranty.	15
Warranty Claims Handling Procedure.	15-16
<u>Repair Parts List</u>	
534, 1034, 1036, and 1040 Repair Parts Drawing.	17
1050-1650 Repair Parts Drawing.	18
Repair Parts Descriptions.	19
<u>Service Records</u>	23
<u>Contact Information</u>	24



TO THE OWNER\OPERATOR

Note: This manual applies to both 40" and 50" travel lifts. If an instruction or illustration is unique to either the 40" or 50" lift it will be so indicated. If it is not so indicated, an instruction or illustration then applies to both the 40" and 50" travel lifts.

Read this manual completely before using your gate. Operate and maintain your gate safely as outlined in this manual. Be sure you read and understand all operating, safety, maintenance and service information. Should you need repair or service information, contact Tommy Gate or an authorized distributor for assistance.



This is the safety alert symbol. It is used to alert you to potential personal injury hazards. Obey all safety messages that follow this symbol to avoid possible injury or death.



!DANGER indicates an imminently hazardous situation which, if not avoided, will result in death or serious injury.



!WARNING indicates a potentially hazardous situation which, if not avoided, could result in death or serious injury.



!CAUTION indicates a potentially hazardous situation which, if not avoided, may result in minor or moderate injury.



CAUTION indicates a potentially hazardous situation which, if not avoided, may result in property damage.

Safety is a primary concern in the design and manufacture of our products. Unfortunately, our efforts to provide safe equipment can be wiped out by a single careless act of an operator.

Accident prevention and safety are dependent upon the awareness, concern, prudence and proper training of the personnel who operate, transport, maintain and store this equipment. It is your responsibility to use good judgment in the operation of this equipment.

It has been said that **"the best safety device is an informed, careful operator."** We ask you to be that kind of operator.



DECAL LOCATIONS AND DESCRIPTIONS

Locate and read all decals prior to operating gate
REPLACE IF MISSING OR NOT READABLE

TOMMY GATE[®]

DO'S

- * DO CENTER YOUR LOAD ON PLATFORM.
- * DO CLOSE AND LOCK LIFT IN CLOSED POSITION WHEN NOT IN USE OR UNATTENDED.
- * DO STAND TO THE SIDE OF LIFTGATE WHILE IT IS IN OPERATION.
- * DO READ MAINTENANCE AND SERVICE INFORMATION.
- * DO READ OPERATOR'S INSTRUCTIONS.
- * DO FREQUENTLY CHECK CABLES, CHAINS, AND OTHER COMPONENTS FOR WEAR OR DAMAGE AND REPAIR AS NECESSARY WITH PARTS PROVIDED BY THE ORIGINAL EQUIPMENT MANUFACTURER.
- * DO CHECK ALL SAFETY DEVICES FOR PROPER OPERATION.

DO NOT'S

- * DO NOT RIDE OR PERMIT ANYONE TO RIDE ON LIFT. THE LIFT IS NOT A PERSONNEL OR WHEELCHAIR LIFT.
- * DO NOT MAKE ANY MODIFICATIONS TO THE LIFT OR ITS SAFETY FEATURES.
- * DO NOT ALLOW USE OF LIFT BY A PERSON WHO HAS NOT HAD PROPER TRAINING IN ITS OPERATION.
- * DO NOT TRY TO LIFT OR LOWER MORE THAN THE RATED CAPACITY OF THE LIFT.
- * DO NOT ADD TO OR REMOVE PARTS OF LIFT AS IT WILL VOID YOUR WARRANTY.
- * DO NOT MOVE VEHICLE UNLESS GATE IS IN LATCHED POSITION.
- * DO NOT SHOW CHILDREN OR UNAUTHORIZED PERSONNEL HOW TO OPERATE LIFT.
- * DO NOT LEAVE PLATFORM OPEN, OR UNLATCHED WHEN LIFT IS NOT IN USE OR UNATTENDED. NEVER LEAVE PLATFORM DOWN TO BE USED AS A STEP.

ALL REPAIRS OR REINSTALLATIONS OF TOMMY GATE LIFTS SHOULD BE PERFORMED BY AN AUTHORIZED DISTRIBUTOR THAT IS FAMILIAR WITH ITS OPERATION AND SAFETY FEATURES. ALL REPLACEMENT PARTS MUST BE OF ORIGINAL QUALITY, AND ALL SAFETY AND OPERATIONAL DECALS MUST BE ATTACHED AND LEGIBLE

9561

Decal No. 1
Place in cab in a highly visible area.

⚠ WARNING

Keep one hand on the platform when opening and closing.

Platform opening and closing forces/weights will vary if your vehicle is on an incline.

Stand clear of all moving parts when opening, raising or lowering platform.

Never leave the platform down to be used as a step.

Do not add any extension to original platform.

9523

Decal No. 2
Located on the outside right-hand corner of the platform.

TOMMY GATE CO.

TOMMY LIFT[®]

PART NUMBER

SERIAL NUMBER

WOODBINE MANUFACTURING CO.
 WOODBINE, IOWA
 (800) LIFTGATE

Decal No. 3
Located on the inside of the main frame.
Positioned over the top of the pump & motor unit.
Located on the passenger side of upright.

⚠ WARNING

Do not ride the platform.

This lift is not designed as a wheelchair or personnel lift.

Center Load

Center load on platform side to side and front to back.

Never allow children or any untrained person to operate the lift.

Do not show children or others how to operate the lift.

When the lift is not in use or unattended, the platform should be closed and latched with control secured.

9522

Decal No. 4
Located on left-hand upright inside the frame.

⚠ DANGER

Keep away from moving parts

9555

Decal No. 5
Located on the side of uprights.

⚠ CAUTION

Spring under high tension

9540

Decal No. 6
Located on the upright next to the torsion spring and safety holder on models with torsion assist spring.

Rated Lift Capacity

XXX lb or XXX kg

500 lbs. 9475
 1000 lbs. 9477
 1300 lbs. 9476
 1600 lbs. 9479

Decal No. 7
Located on the front of the control shield.

DECAL LOCATIONS AND DESCRIPTIONS

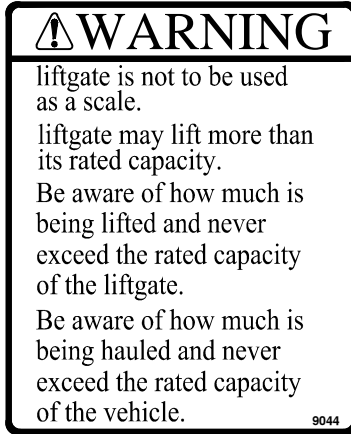

Decal No. 10
Located next to the control shield.



Decal No.11
Located on the front of the control shield.

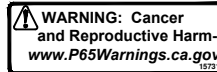

Decal No. 12
Located on the side of the control.

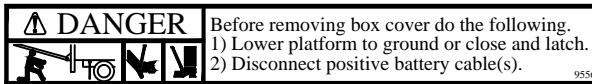

Decal No. 13
Located on box cover of gate.

DECAL REPLACEMENT

NOTE: When ordering Decals, please have Decal Numbers available.

To replace decal, clear area of grease and dirt with non-flammable solvent and soap and water. Allow to dry. To apply decal, peel off 1/2 of back. Hold decal squarely and apply to cleaned surface. Peel off remaining back and smooth in place. Gently rub decal with a damp rag or sponge to smooth out bubbles. (The decal has a pressure-sensitive adhesive on the back.)

If the liftgate is going to be painted, you need to mask the decals before painting. Remove the mask after painting so the decals can be read clearly.



ORIGINAL SERIES TERMS AND METHOD OF OPERATION

Your Tommy Gate is connected to your vehicle battery. The vehicle battery powers a motor, coupled to a hydraulic pump. This motor and pump combination is called a power unit. Flow from the pump extends a cylinder to provide tension to the lift cables that lift the gate platform.

!Warning: liftgate is not to be used as a scale. liftgate may lift more than its rated capacity. Be aware of how much is being lifted and never exceed the rated capacity of the liftgate. Be aware of how much is being hauled and never exceed the rated capacity of the vehicle.

The gate platform is lowered by gravity after an electric "release" valve is activated and opened at the power unit.

Tommy Gate's control incorporates a "Low Voltage" warning feature. A "Low Voltage" condition exists when the "Power On" button is armed and 7 Volts or less is present at the power unit. This "Low Voltage" feature is designed to warn the operator that there is a low voltage condition and that it should be corrected as soon as possible. The amber "Power On" LED will blink to warn the operator of this condition. When this light is blinking, it will not prevent the control from functioning to raise or lower the gate. In a "Low Voltage" situation, whether the gate actually raises or lowers depends on how low the voltage is.

Caution: Continuing to operate the the liftgate in the "Low Voltage" condition may result in failure of electrical components in the power unit.

The low voltage condition may be caused by a weak battery, loose or corroded connections, improper ground, or bad electrical cables. This condition may be corrected by just starting the vehicle or replacing the battery.

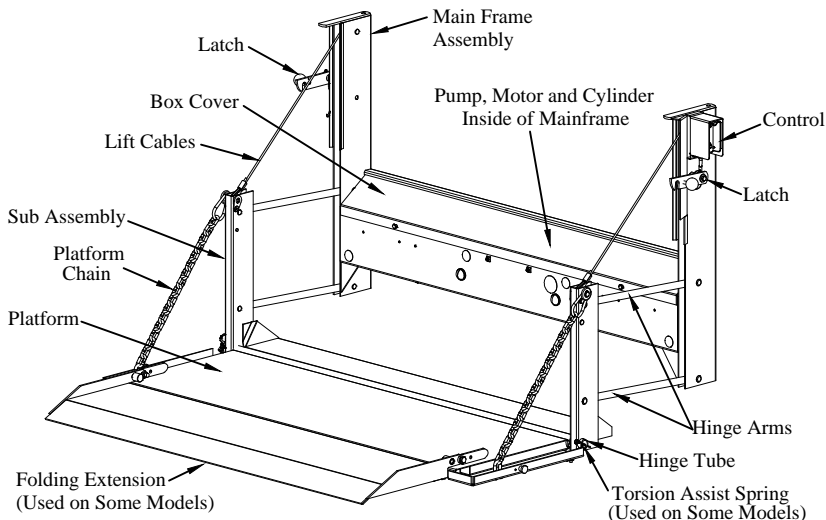

!Caution:

**Never leave the truck with the platform on the ground, partially raised, or open.
Never show children or unauthorized personnel how to operate the gate.**

To prevent children or unauthorized personnel from operating the lift, be sure the gate is in the stored position and both the driver's side and passenger's side latches are secured. Make sure the passenger's side latch padlock is installed and the control is deactivated before leaving the truck unattended.

!Warning: The Tommy Gate is an industrial product for material handling only and is not to be used as a personnel or wheelchair lift. Do not ride on the platform and always stand clear of the platform when opening, raising or lowering.

Step 1. To open the platform, go to the driver's side of the Tommy Gate and unsecure by lifting the latch off the platform pin and rotate the latch away from the platform. Proceed to the passenger's side of the Tommy Gate and remove the latch padlock (Figure 1). Now lift the passenger's side latch off the platform pin with one hand while holding the top of the platform with your other hand. Now pull the platform open and step away from the platform as it opens.

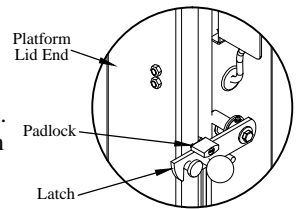

Figure 1

Step 2. If the gate is on an application with swing out doors, you can open them at this time.

Step 3. Be sure to stand clear of the platform and all moving parts when using the lift.

- Step 4. To turn the control power on, press the "POWER ON" hidden switch once, marked with black rings or circles (located between the Tommy Gate logo and the toggle switch). You should see the amber LED "POWER ON" light when the control is armed. To disarm the control, press the "POWER ON" hidden switch again.
- Step 5. To activate the control, press the "LIFTGATE ACTIVATED" hidden switch twice within one second (located under the Tommy Gate logo). You should see the red "LIFTGATE ACTIVATED" light when the control is activated.

Note: After you have activated the control, you have approximately 90 seconds to use the gate. If the gate is not used for approximately 90 seconds, the "LIFTGATE ACTIVATED" timer deactivates the control. If the gate is used during the 90 seconds, the "LIFTGATE ACTIVATED" timer automatically resets for an additional 90 seconds. To reactivate the timer, press the "LIFTGATE ACTIVATED" hidden button twice within one second.

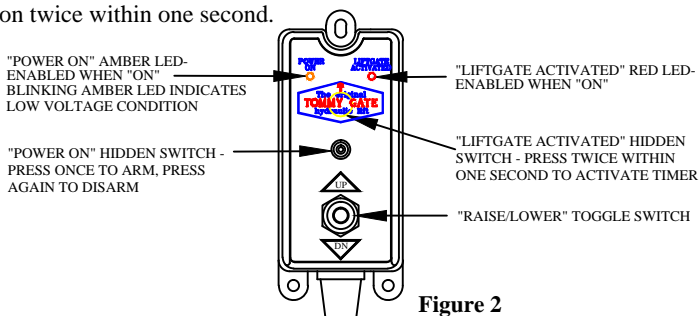

Figure 2

- Step 6. To **lower** the platform, stand to the side clear of the platform and all moving parts, then push the toggle switch down. When you remove pressure from the toggle switch, the operation will stop.
- Step 7. To **load** and use the Tommy Gate, center the load on the platform side to side and front to back. Put heavier loads as close to the front of the platform (near truck) as possible.
- Step 8. To **raise** platform, stand off to the side, well clear of the platform and all moving parts. Push up on the toggle switch until the platform has reached the desired position. When you remove pressure from the toggle switch, the operation will stop.

Caution:

Do not allow the pump and motor to continue to run after the platform has reached its maximum height or after it has reached an obstruction.

- Step 9. When the platform is raised to the level of the vehicle's floor and the load is removed from the platform, close the platform and folding extension (if so equipped) by hand. The latch on the passenger's side will secure itself. Go to the driver's side and lift the latch and hook it onto the pin of the platform. Install the padlock (Figure 1).

PLATFORM DROP AWAY FEATURE

Install platform drop away pin (Figure 3).

1. **Insert** the platform drop away pin through the existing 3/8" hole in the upright back.
2. **Fasten** the pin to the upright using the supplied 3/8" nut.

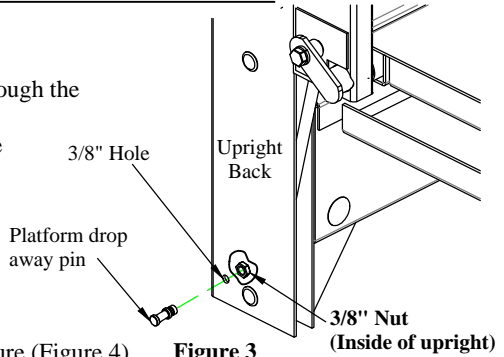

Figure 3

Prepare chain for platform drop away feature (Figure 4).

1. **Unhook** both platform chains from the sub-assembly pins.

!Caution - The platform may spring back with great force if released under pressure.

2. **Push** the platform down and **pull** driver side chain toward the drop away pin on the upright.
3. **Mark** the position of the cloth cover that is next to the drop away pin.
4. **Slowly release** the platform allowing the spring tension to lessen.
5. **Cut** a 1" slit in the cloth cover.

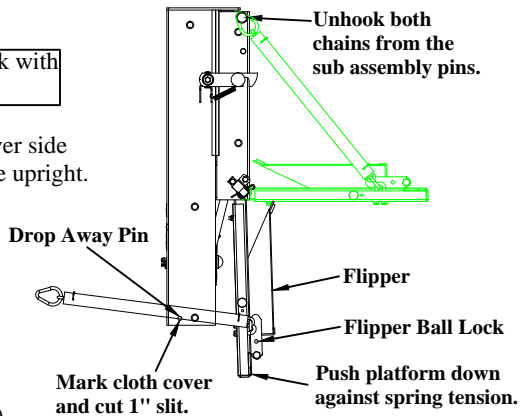

Figure 4

Use platform drop away feature (Figure 5).

1. **Unhook** both platform chains from the sub-assembly pins.
2. **Pull** chain link through slit cut in driver side chain cover.

!Caution - The platform may spring back with great force if released under pressure.

3. **Push** the platform down and **hook** exposed link over drop away pin on the upright.

Caution - If equipped the platform flipper may fall open and contact the ground if the ball locks on the platform are not in good working order.

Hook exposed chain link to drop away pin on driver side upright.

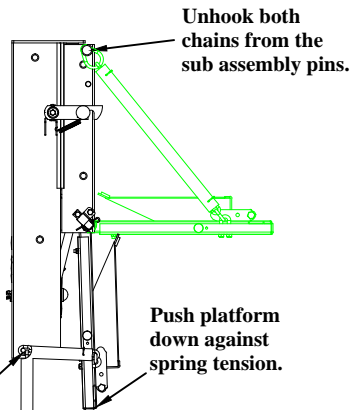

Figure 5

Disable platform drop away feature.

1. Reverse order of above instructions.

ELECTRICAL WIRING DIAGRAM

Standard Fixed Control



WELDING NOTE !!! DISCONNECT ALL BATTERY CABLES. ALWAYS DISCONNECT THE GROUND CABLE FIRST. ATTACH THE WELDING GROUND TO THE TRUCK RATHER THAN THE LIFTGATE.



!!! PLEASE READ AND FOLLOW ALL DIRECTIONS BEFORE PROCEEDING !!!



NOTE !!! IF GATES ARE NOT WIRED IN ACCORDANCE WITH THIS DIAGRAM YOUR WARRANTY WILL BE VOID.

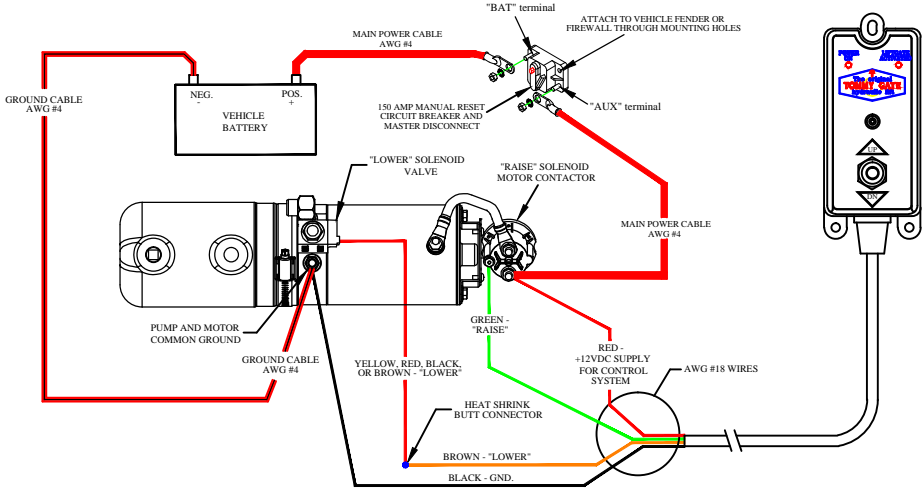

CONTROL OPERATION

BLINKING AMBER LED INDICATES LOW VOLTAGE CONDITION

"RAISE/LOWER" TOGGLE SWITCH

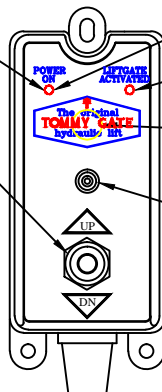

"POWER ON" AMBER LED - ENABLED WHEN "ON"

"LIFTGATE ACTIVATED" RED LED - ENABLED WHEN "ON"

"LIFTGATE ACTIVATED" HIDDEN SWITCH - PRESS TWICE WITHIN ONE SECOND TO ACTIVATE TIMER

"POWER ON" HIDDEN SWITCH - PRESS ONCE TO ARM, PRESS AGAIN TO DISARM

ELECTRICAL WIRING DIAGRAM

Optimal Pendant Control



WELDING NOTE !!! DISCONNECT ALL BATTERY CABLES. ALWAYS DISCONNECT THE GROUND CABLE FIRST. ATTACH THE WELDING GROUND TO THE TRUCK RATHER THAN THE LIFTGATE.



!!! PLEASE READ AND FOLLOW ALL DIRECTIONS BEFORE PROCEEDING !!!



NOTE !!! IF GATES ARE NOT WIRED IN ACCORDANCE WITH THIS DIAGRAM YOUR WARRANTY WILL BE VOID.

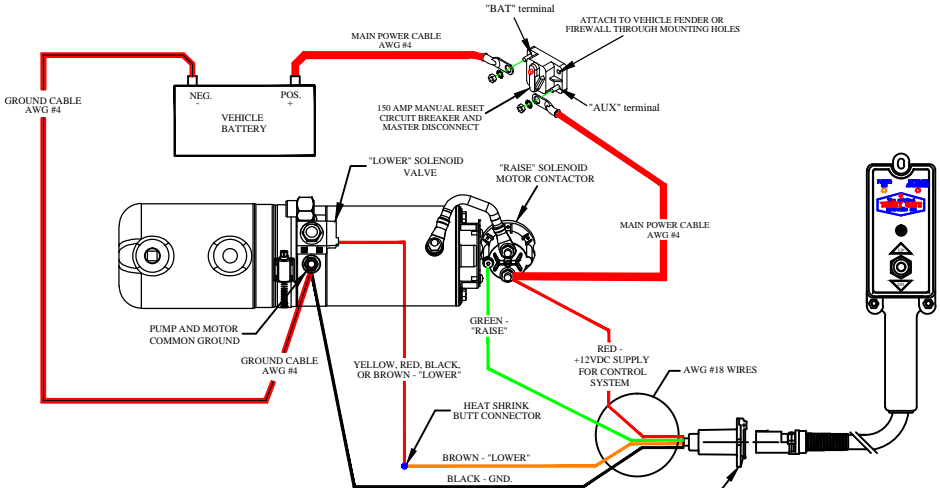

COLE HERSEE SOCKET END	
POSITION	WIRE COLOR
S	BLACK
RT	GREEN
LT	NO WIRE
TM	BROWN
A	NO WIRE
GD	RED

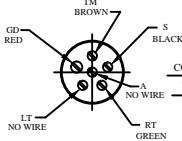

CONTROL OPERATION

BLINKING AMBER LED INDICATES LOW VOLTAGE CONDITION

"RAISE/LOWER" TOGGLE SWITCH

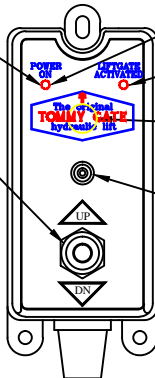

"POWER ON" AMBER LED - ENABLED WHEN "ON"

"LIFTGATE ACTIVATED" RED LED - ENABLED WHEN "ON"

"LIFTGATE ACTIVATED" HIDDEN SWITCH - PRESS TWICE WITHIN ONE SECOND TO ACTIVATE TIMER

"POWER ON" HIDDEN SWITCH - PRESS ONCE TO ARM, PRESS AGAIN TO DISARM

POWER UNIT CONTROL CIRCUIT

Legend	
	Solenoid contact
	Motor
	Solenoid coil
	Circuit breaker with manual disconnect and reset
	Battery cable
	Primary Wire
	Grounded through motor chassis
	Elements within are part of the control
	Positive 12V
	Negative battery terminal or frame ground

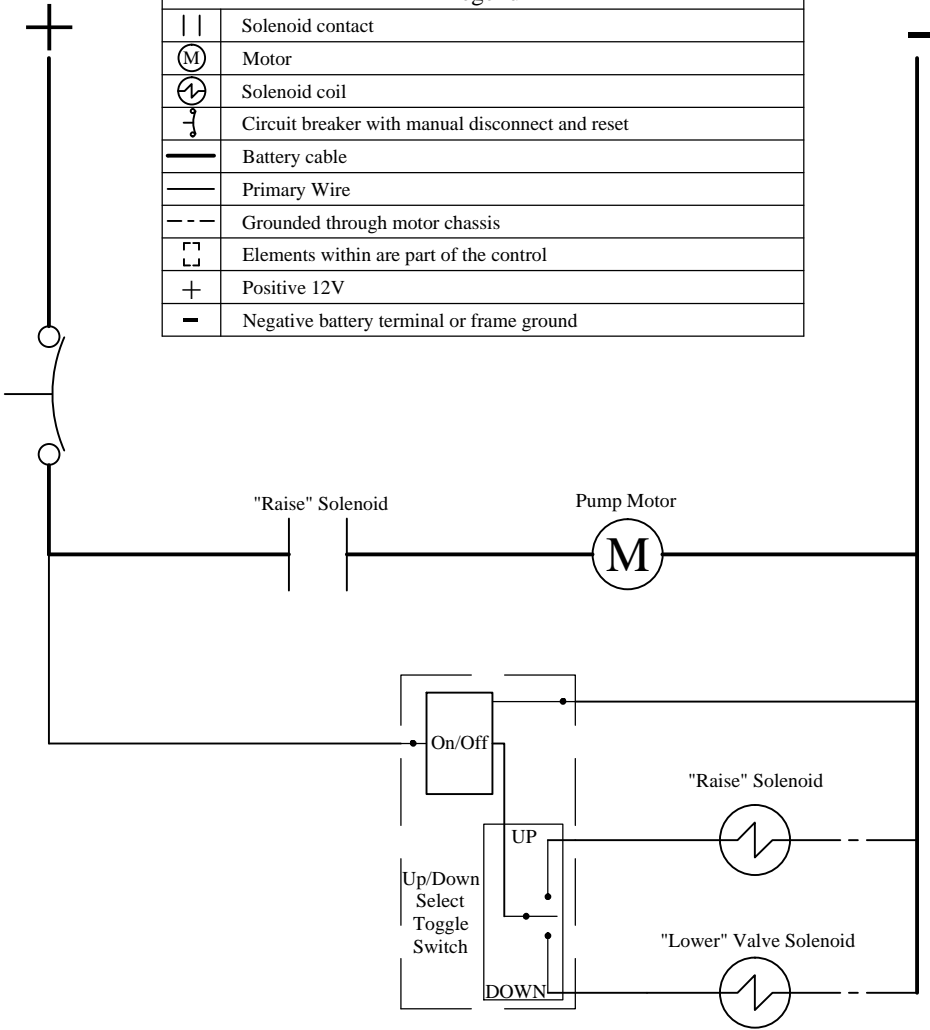



MAINTENANCE AND SERVICE INFORMATION

The Tommy Gate Original Series liftgate needs to be serviced every 60 days , unless otherwise noted, under normal use (275-325 cycles).

The lift will not be automatically serviced when the vehicle is serviced.

If there is any noticeable problem with the liftgate between service intervals, the liftgate must be taken out of service and checked immediately.

As is with any mechanical product, a preventive maintenance program needs to be followed in order to keep it in its best operating condition. Please review this information and if you should have any questions please call 712-847-8000. Please have your model number and serial number available.

All installations, re-installations, and repairs of Tommy Gate Original Series liftgates should be performed by a qualified authorized distributor that is familiar with its operation and safety features. All replacement parts must be of original quality, and all safety and operational decals must be attached. No modifications are allowed to a Tommy Gate product unless authorized in writing by the Engineering Department at Tommy Gate.

MAINTENANCE PROCEDURE

- (A) Lower the platform to the ground and remove the box cover.
- (B) Inspect steel lift cables and platform chains (every 30 days) for any wear or fraying. If either is found, replace immediately with Tommy Gate Company parts.
- (C) Check for fluid leaks from the cylinder, hoses, and all fittings (replace or repair if found to be leaking).
- (D) Check the oil level in the reservoir. With the liftgate platform at the bottom of its travel, the fluid should be two-thirds full. **BE SURE THE CYLINDER IS COMPLETELY COLLAPSED.** Add Tommy Gate winter grade, ISO grade 32 hydraulic, or Dexron III/ Mercon ATF if needed.
- (E) Grease pulley grooves as this will help the cables remain flexible, giving you added service.
- (F) Grease all zerk fittings with ample amount of grease (every 30 days).
- (G) Check the inside of the box for excessive accumulation of dirt. Clean as necessary.
- (H) Replace any worn or missing parts before the liftgate is put back into service.
- (I) If needed, adjust platform latches which are designed to hold the liftgate in a properly stored position.
- (J) Check for wear at all pivot points.
- (K) Check electrical cables for wear or damaged insulation. Check all electrical connections. (clean or repair if needed).
- (L) Replace or clean safety decals so they are legible.
- (M) Check the welds on the liftgate, its mounting brackets and on the adjacent vehicle structure for cracks or damage. Repair any cracks or damage.
- (N) Check the torque on all mounting bolts and re-tighten as necessary.
- (O) Check for proper operation of the control.

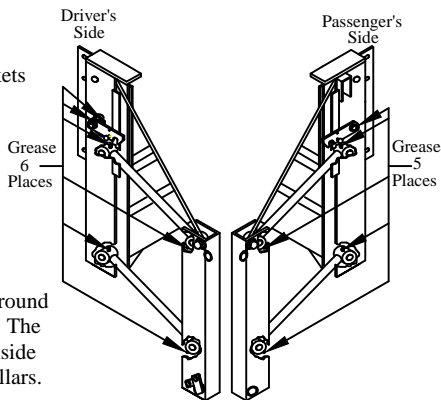

NOTE: Lower the liftgate to the ground to grease the liftgate arms. The grease zerks are located inside the uprights on the arm collars.



TROUBLESHOOTING - 500-1600 LB ORIGINAL SERIES

PROBLEM	POSSIBLE CAUSE	REMEDIES
1.) Lift will not operate - "POWER ON" amber LED light does not come on.	<ul style="list-style-type: none"> a.) Control not armed properly. b.) Poor electrical connection. c.) Polarity is reversed. d.) Circuit breaker tripped or disengaged. e.) Faulty control. 	<ul style="list-style-type: none"> a.) Turn the power on at the control by pressing the "POWER ON" hidden switch, marked with white rings or circles (located between the Tommy Gate logo and the toggle switch). b.) Check and repair or replace all cables and connections. c.) Switch positive and negative cables. d.) Check for short, then manually engage circuit breaker. e.) Replace Control.
2.) Lift will not operate - "LIFTGATE ACTIVATED" red LED light does not come on.	<ul style="list-style-type: none"> a.) Control not activated properly. b.) Faulty control. 	<ul style="list-style-type: none"> a.) Press the "LIFTGATE ACTIVATED" hidden switch twice within one second (located under the Tommy Gate logo). The red "LIFTGATE ACTIVATED" LED light should come on. b.) Replace control.
3.) Blinking amber "POWER ON" LED.	<ul style="list-style-type: none"> a.) Low voltage condition. b.) Poor grounds or connections. c.) Power connected or reconnected since last use. 	<ul style="list-style-type: none"> a.) Check and clean or repair all electrical connections. Load test battery, then recharge or replace battery, if required. b.) Repair, replace, clean as necessary. c.) Normal, press bullseye once to activate solid "POWER ON" amber LED.
4.) Lift will not raise or raises slowly - control working properly.	<ul style="list-style-type: none"> a.) Poor electrical connection. b.) Battery charge is low. c.) Release valve stuck partially open or dirty. d.) Release valve needs replacement. e.) "Raise" solenoid not working. f.) Oil level low. g.) Vent plug not installed or dirty. h.) Overloaded liftgate. 	<ul style="list-style-type: none"> a.) Check power and ground cables and all connections. b.) Recharge or replace battery. c.) Raise platform completely and continue to run pump for 5 seconds. d,e) Contact Tommy Gate or distributor. f.) Check oil and add ISO grade 32, Tommy Gate winter grade hydraulic, or Dexron III/Mercon ATF. g.) Check vent plug on pump tank. A red shipping plug is installed at factory. It must be replaced by the metal vented plug. h.) Remove some material or weight.
5.) Lift settles down slowly with load or no load.	<ul style="list-style-type: none"> a.) Hoses or fittings leaking. b.) Check valve stuck or dirty. c.) Check valve damaged. d.) Cylinder seals worn or damaged. e.) Down solenoid sticking partially open. 	<ul style="list-style-type: none"> a.) Tighten or replace. b.) Raise and lower lift several times to flush out valve. c,d,e.) Contact Tommy Gate or distributor for repair or replacement.
6.) Pump or motor noisy.	<ul style="list-style-type: none"> a.) Worn pump, motor or coupling. b.) Oil level low 	<ul style="list-style-type: none"> a.) Contact Tommy Gate or distributor. b.) Check oil and add ISO grade 32, Tommy Gate winter grade hydraulic, or Dexron III/Mercon ATF.
7.) Lift lowers very slowly, especially in cold weather.	<ul style="list-style-type: none"> a.) Cold, thick, oil. b.) Lack of lubrication at hinge arm pins. c.) Pins seized due to lack of lubrication. d.) Kicker springs broken. 	<ul style="list-style-type: none"> a.) Check oil type. Add winter grade Tommy Gate hydraulic or Dexron III/Mercon ATF. b.) Lubricate all zerks. c.) Replace pins. d.) Replace kicker springs.
8.) Lift will not lower.	<ul style="list-style-type: none"> a.) Control not armed and activated - No amber "POWER ON" LED or red "LIFTGATE ACTIVATED" LED light on. b.) Poor electrical connections. c.) Lift stuck or sprung, if control is working properly. d.) If control working properly, damaged or non-working release solenoid. e.) Hinge arm or cylinder pins seized. 	<ul style="list-style-type: none"> a.) Press the "POWER ON" hidden switch, marked with white rings or circles (located between the Tommy Gate logo and the toggle switch). The amber "POWER ON" LED light should come on. Now press the hidden "LIFTGATE ACTIVATED" switch twice within one second (located under the Tommy Gate logo). The red "LIFTGATE ACTIVATED" LED light should come on. b.) Check and clean or repair all electrical connections. c.) Apply downward load on platform, pry away upright sides. d.) Contact Tommy Gate or distributor. e.) Lubricate or clean and/or replace pins.
9.) Lift will not raise all the way.	<ul style="list-style-type: none"> a.) Oil level low. b.) Vent plug not installed or dirty. c.) Poor electrical connections. d.) Cables improperly adjusted. 	<ul style="list-style-type: none"> a.) Check oil and ISO grade 32, Tommy Gate winter grade hydraulic, or Dexron III/Mercon ATF. b.) Check vent plug on pump tank. A red shipping plug is installed at the factory. It must be replaced by the metal vented plug. c.) Check and repair or replace all cables and connections. d.) Adjust cables with cylinder completely collapsed and gate platform at fully lowered position.



ORIGINAL SERIES WARRANTY GUIDELINES

A. STANDARD WARRANTY

The Tommy Gate Company provides a limited warranty against faulty materials or workmanship.

Tommy Gate pump and motor unit parts are guaranteed for two (2) full years from the date of purchase against faulty materials or workmanship.

Tommy Gates are warranted for one (1) year from the date of user purchase against faulty materials or workmanship.

All affected parts must be returned to the factory prepaid - with full credit issued for those found to be defective. Warranty replacement parts will be shipped from the factory prepaid.

Labor charges to install warranty replacement parts shall be paid in accordance with Tommy Gate's estimated repair time guide and a flat hourly rate established by Tommy Gate. **DEVIATION FROM THE WARRANTY TIMES LISTED MUST BE AUTHORIZED BY TOMMY GATE COMPANY IN ADVANCE.**

The warranty does not include damage resulting from improper installation procedures. Parts must be installed according to Tommy Gate Company's specifications.

Tommy Gate Company will not pay labor for removing other equipment to gain access to Tommy Gate Equipment. Tommy Gate Company will not pay labor for time on the road to and from a service call.

Tommy Gate Company reserves the right to disallow or reduce claims for parts which have been damaged due to misuse, abuse, accidents or improper shipping; or parts which have been incorrectly or unnecessarily replaced.

The warranty is void if the product has been subject to other than normal use. **THERE ARE NO WARRANTIES, EXPRESS OR IMPLIED, INCLUDING THE WARRANTY OF MERCHANTABILITY OR A WARRANTY OF FITNESS FOR A PARTICULAR PURPOSE EXTENDING BEYOND THAT SET FORTH ABOVE.**

B. WARRANTY CLAIMS HANDLING PROCEDURE:

The following procedures are required when an authorized distributor submits a warranty claim for a defective Tommy Gate part:

1. Before any expense is incurred, but after the problem has been diagnosed, the authorized distributor should contact Tommy Gate Company's Warranty Department to discuss the problem and its correction.
2. If it is determined that the condition is potentially covered by Tommy Gate Company's warranty, the authorized distributor will receive instructions on how to proceed. A decision will be made to either repair or replace the product or part in question.



ORIGINAL SERIES WARRANTY GUIDELINES

3. If the product or parts are to be repaired, the authorized distributor will receive a **WARRANTY REQUEST NUMBER**.
4. If the product or parts are to be replaced, the authorized distributor will be instructed to either hold the parts for inspection by a representative, in which case the authorized distributor will receive a **WARRANTY REQUEST NUMBER**, or the authorized distributor will be asked to return the product for inspection to Tommy Gate Company, in which case the authorized distributor will receive a **RETURN GOODS AUTHORIZATION NUMBER**. Under no circumstances are parts to be returned without a **RETURN GOODS AUTHORIZATION NUMBER**.
5. After the repair or replacement work is completed, the authorized distributor will submit the claim to Tommy Gate Company with the following information:
 - a. Tommy Gate Company **WARRANTY REQUEST** and/or **RETURN GOODS AUTHORIZATION NUMBER**.
 - b. Tommy Gate model number.
 - c. Tommy Gate serial number.
 - d. Tommy Gate part number involved and a description of the apparent problem or defect.
 - e. Authorized distributor performing warranty work.
 - f. Person responsible for warranty work (contact).
 - g. Distributor from whom liftgate was purchased.
 - h. liftgate owner's name, address, and phone number.
 - i. Action taken, cost involved, complete with work orders and parts expense invoices.
6. If defective parts are to be returned to Tommy Gate Company, the parts:
 - a. Must be packaged for each individual warranty return. No multiple warranty claims in the same box.
 - b. Must be returned "freight prepaid" to Tommy Gate Company's location.
 - c. Must be clearly marked with the **RETURN GOODS AUTHORIZATION NUMBER** on the outside of the package.

Warranty claims must be submitted by the Authorized Distributor on behalf of their customer as part of their customer assistance.

Warranty claim acceptance or rejection is based solely upon defective part inspection and a review of the claim date (outlined in step 5 above) as they apply to the requirements of the Tommy Gate Warranty. Claim reimbursement after acceptance is governed by those allowances previously agreed upon between Tommy Gate Company and the Authorized Distributor (as outlined in steps 1-4 above).

Any warranty claims submitted without a **WARRANTY REQUEST NUMBER** or **RETURN GOODS AUTHORIZATION NUMBER** and the necessary information will be denied.

534, 1034, 1036, AND 1040 ORIGINAL SERIES REPAIR PARTS DRAWINGS

FOR MODELS 48, 54, 60, 64, 64P & 72P

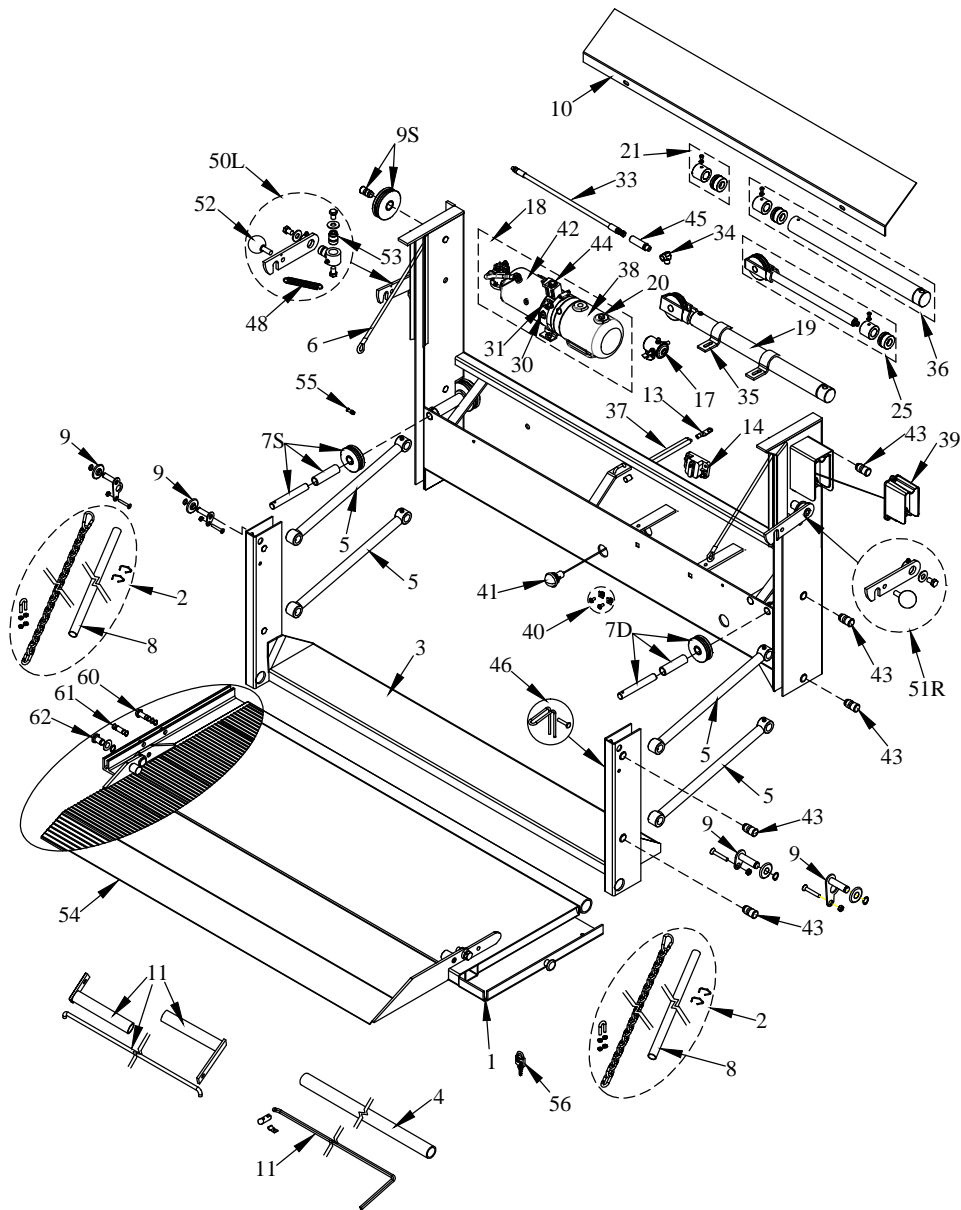

1050-1650 ORIGINAL SERIES REPAIR PARTS DRAWING

FOR MODELS 64SB, 72, 80, 86 & 91

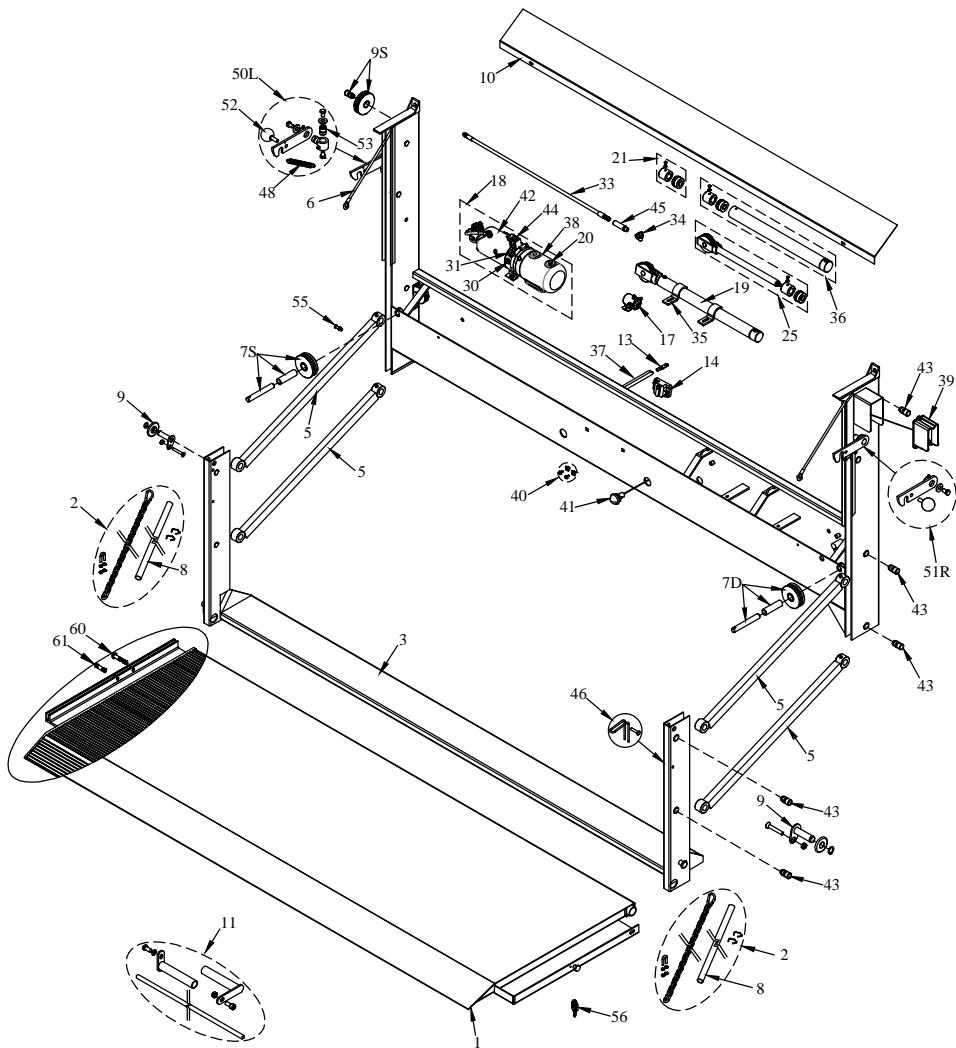



500-1600 LB ORIGINAL SERIES REPAIR PARTS LIST

ITEM#	DESCRIPTION	ITEM#	DESCRIPTION
1	Platform	38	Tank
2	Platform Chain	39	Timed Control
3	Sub Assembly	40	License Plate Mount Kit
4	Hinge Tube	41	License Plate Light
5	Lift Arm	42	Motor Only
6	Lift Cable	43	Arm Pin
7D	Double Pulley(Mainframe)	44	Release Solenoid
7S	Single Pulley(Mainframe)	45	Flow Control
8	Cloth Chain Cover	46	Kick Away Spring
9	Cable Pin Assembly	48	Latch Spring
9S	Single Pulley(Upright)	50L	Driver's Side Latch
10	Box Cover	51R	Passenger's Side Latch
11	Torsion Spring	52	Latch Knob w/Stud
13	Copper Lug	53	Threaded Latch Bushing
14	150 Manual Reset Circuit Breaker	54	Flipper
17	Raise Solenoid	55	Drop Away Pin Assembly
18	Pump & Motor	56	Padlock w/ Keys
19	Cylinder	60	EA Latch Rivet
20	Vent Plug	61	EA Platform Chain Pin
21	Cylinder Repair Kit	62	EA Flipper Rivet
25	Cylinder Shaft w/Pulley		
30	Monarch Lee Check Valve		
31	90° Pump Elbow		
33	Hydraulic Hose		
34	90° Cylinder Elbow		
35	Cylinder Clamp		
36	Cylinder Barrel		
37	4ga. 2 Wire Electric Cable		

Note:

The item number **is not** the part number. Please have the model number and serial number available before calling for repair parts.



THIS PAGE
INTENTIONALLY LEFT
BLANK



THIS PAGE
INTENTIONALLY LEFT
BLANK



THIS PAGE
INTENTIONALLY LEFT
BLANK



**America's First Name
in Liftgates™**

Manufacturing Plant:
83 Bus Brown Drive
Woodbine, Iowa 51579
FAX (712) 647-2417

Corporate Offices:
33717 N. Scottsdale Rd. Ste 120
Scottsdale, AZ 85266
FAX (602) 955-3902

(712) 847-8000
www.tommygate.com

