

# *Anthony Magnum RailTrac<sup>TM</sup> Heavy Duty Hydraulic Liftgates<sup>®</sup>*



*Lifting Capacities: 3,500 lb. 4,500 lb. 5,500 lb. 6,500 lb*



**ANTHONY**  
**LIFTGATES, INC.<sup>®</sup>**

## **Anthony: Industry Leader**

Anthony Liftgates has been the driving force in the industry since 1941, producing innovative designs and quality products for trucks of all sizes. Our factory support is unmatched in the industry, providing dealers and their customers coast to coast with prompt delivery of products, parts orders, and custom engineering requests. Looking for a product you can stake your reputation on? Anthony Liftgates offers a wide range of models backed by the best warranty in the business. For performance, dependability, and value, Anthony delivers the complete package for every application!

### **Dual Pump and Motor Hydraulic Drive System**

Twin pumps, motors, and solenoids handle the work with half the effort required of a typical

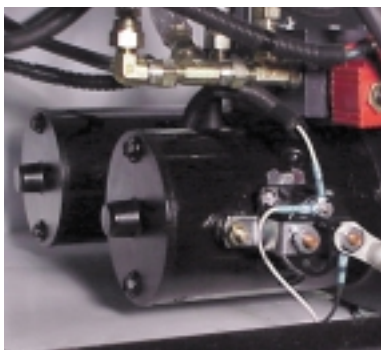

single-pump tailgate system, resulting in a longer and more dependable service life.

### **ZLC™ Zero Leak Concept**

The use of machined fittings, SAE "O" ring and JIC hydraulic connections, along with factory installed -70° low pour



hydraulic fluid, mean you'll have long, trouble-free service with no aggravating and costly leaks.



### **Lifetime Warrantied Service-Free™ Sliders**

Inside the vertical tracks there are no rollers or roller bearings to wear or replace. This can mean savings of thousands of dollars over the life of the Liftgate®.

### **Self-Aligning Cylinder Attachment Ends**

Platform lift cylinders are mounted on self-aligning swivel



ends that prevent sideloading of cylinder pistons and internal cylinder wall scoring.

### **Service-Free Bushings**

Used at critical pivot points, these bushings extend pin and



arm life and eliminate routine lubrication.

### **Bolt-on Switch Box**

The switch box housing is easily removable for quick & easy, efficient servicing or



replacement. Inside, heat-shrink siliconed wire connections seal out moisture and stainless steel terminals provide extra corrosion protection.

# Quality Standard Features:

## **Tail Lights**

Prewired and pigtailed for easy hookup.

## **Galvaneal Power Unit Enclosure**

Separate vented battery compartment for two 12 volt batteries.

## **Marine-Duty Sealed Toggle Switch**

Operates reliably under all types of weather conditions.

## **Pressure Compensated Flow Valve**

Provides constant and controlled lowering speed of the platform, loaded or unloaded.

## **Closed Hydraulic System**

Provides positive protection against outside dust, dirt, and moisture; protects against hydraulic contamination.

## **Yellow Di-Chromate Plated Pivot Pins**

Resist corrosion to increase service life.

## **Heat-Shrink Siliconed Wire Connections**

Prevent electrical failure by sealing out moisture at all electrical connections and stainless steel terminals provide extra corrosion protection.

## **Hard Chrome Plated Piston Rod**

Helps keep exposed surface free of rust and contamination to protect seals and extend cylinder life.

## **Relief Valve**

Prevents overloading during lifting cycle.

## **Factory Installed Hydraulic Fluid**

Prevents contamination during field installation and ensures proper SAE fluid.

## **Powered Platform**

Toggle-switch controlled hydraulic system provides easy opening and powered closing.

## **Powder Coated Finish**

Provides attractive, long-life protective finish.

## **Circuit Breaker**

Protects truck wiring and power system in the event of a "dead short."

## **Factory Assembled, Tested, and Energized**

Assures consistent, high-quality performance standards.

## **E-Z Mount Installation**

Shipped completely pre-assembled for fast, clean, easy installation.

## **Cut-Off Switch**

Protects valuable liftgate equipment from unauthorized use or vandalism.

## **Exclusive 2 + 1 Warranty**

2 years on mechanical components;  
1 year on the hydraulic system, parts and labor.

## **Heavy-Duty Construction**

Thick, 5/16 inch vertical rails and 1/2 inch thick overlays on the lower rail creates massive 13/16 inch thick dock contact area.



Gate shown in lowered position for dock loading



Optional bed height model in stored position



Optional 16" aluminum retention ramp

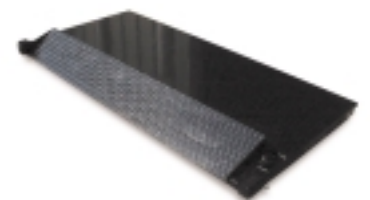

12" pop-up cart stop (Standard)

# Available Models, Platforms and Capacities

Model	Lifting Capacity (lbs.)	Bed Height Min-Max	Platform Load Area and Ramp	Approx. Outside Width	Shipping Wt. (lbs.)
MRT-3500-SF	3,500	38"-58"	80" x 60"+12" ramp w/pop-up cart stop	96"	2,353
MRT-3500-SF	3,500	38"-58"	80" x 72"+12" ramp w/pop-up cart stop	96"	2,413
MRT-3500-SF	3,500	38"-58"	80" x 84" butt edge w/o ramp	96"	2,465
MRT-4500-SF	4,500	38"-58"	80" x 60"+12" ramp w/pop-up cart stop	96"	2,412
MRT-4500-SF	4,500	38"-58"	80" x 72"+12" ramp w/pop-up cart stop	96"	2,452
MRT-4500-SF	4,500	38"-58"	80" x 84" butt edge w/o ramp	96"	2,514
MRT-5500-SF	5,500	38"-58"	80" x 60"+12" ramp w/pop-up cart stop	96"	2,463
MRT-5500-SF	5,500	38"-58"	80" x 72"+12" ramp w/pop-up cart stop	96"	2,503
MRT-5500-SF	5,500	38"-58"	80" x 84" butt edge w/o ramp	96"	2,565
MRT-6500-SF	6,500	38"-58"	80" x 60"+12" ramp w/pop-up cart stop	96"	2,504
MRT-6500-SF	6,500	38"-58"	80" x 72"+12" ramp w/pop-up cart stop	96"	2,544
MRT-6500-SF	6,500	38"-58"	80" x 84" butt edge w/o ramp	96"	2,606

All specifications subject to change without notice.

## Options for the Magnum RailTrac-SF Series

- Power down (switched on demand by operator)
- Hand-held control with plug and socket
- 102" wide models
- Auxiliary hand pump (not available if power down option is selected)
- 16" aluminum retention ramp
- Hose and wire channel mounting kit
- Pump and motor extension kit
- Header kit
- Trailer wiring kits
- Bed height stored model

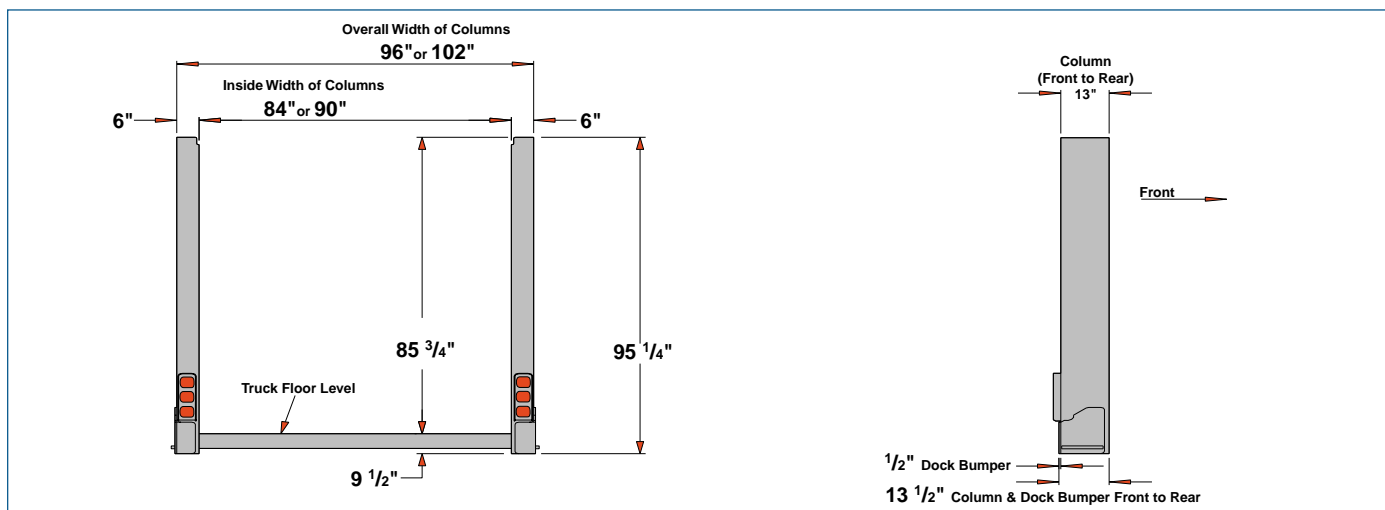

## ANTHONY LIFTGATES, INC.®

Anthony Liftgates, Inc.  
1037 W. Howard Street  
P.O. Box 615  
Pontiac, IL 61764-0615  
Phone: 815.842.3383  
Fax: 815.844.3612  
Toll Free: 800.482.0003  
www.anthonyliftgates.com