

TVL SERIES

All Aluminum Railgates By THIEMAN

TVL125, TVL125A, TVL16, TVL16A, TVL20, TVL20A OWNERS MANUAL/PARTS LIST

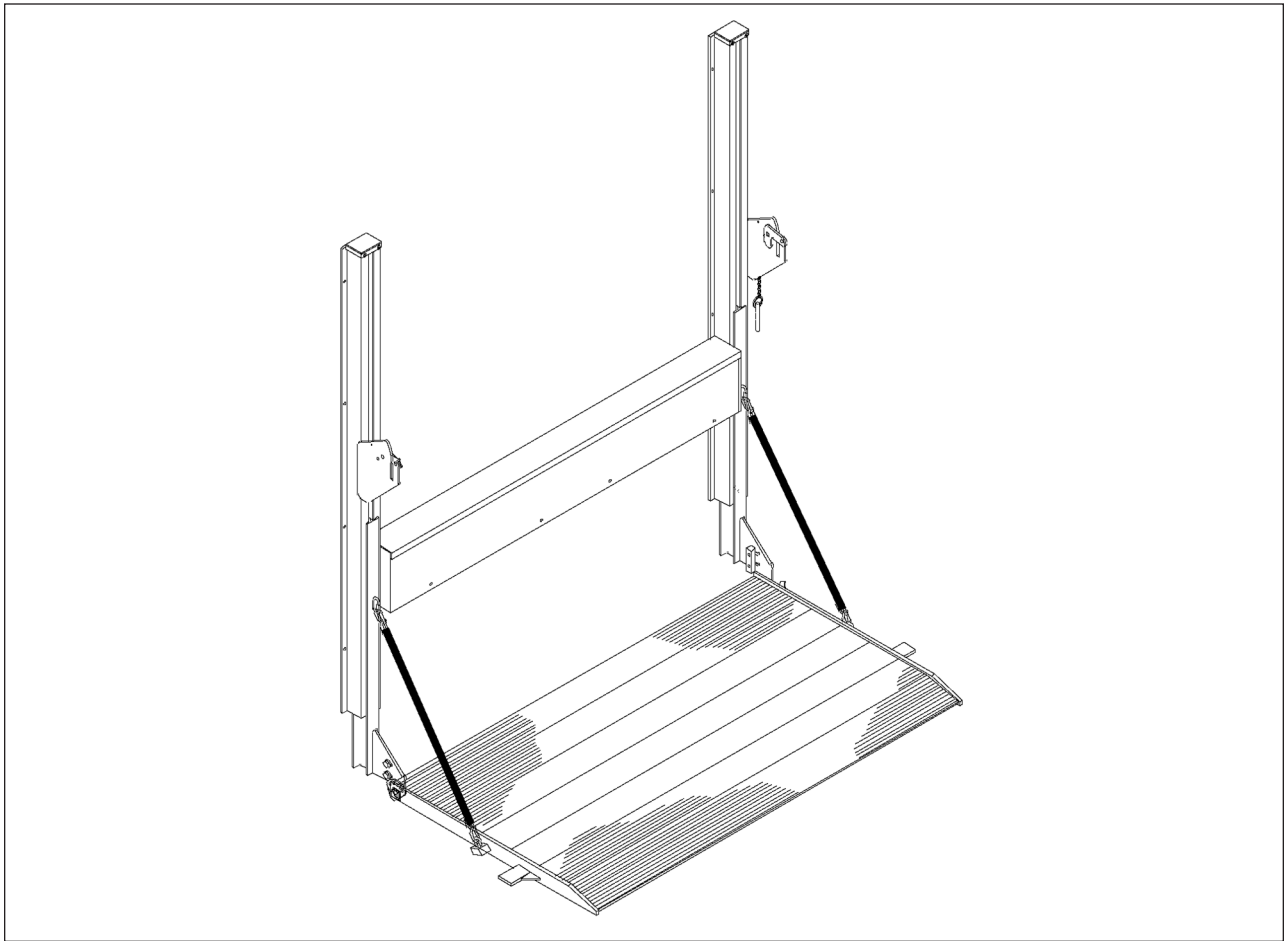

IMPORTANT! KEEP IN VEHICLE!

PLEASE READ AND UNDERSTAND THE CONTENTS OF THIS
MANUAL BEFORE OPERATING THE EQUIPMENT.

THIEMAN
TAILGATES, INC.

600 East Wayne Street
Celina, Ohio 45822

Phone: 419-586-7727 Fax: 419-586-9724

NTEA
THE ASSOCIATION FOR THE WORK TRUCK INDUSTRY
MEMBER

TABLE OF CONTENTS

PARTS ORDERING PROCEDURE	2
WARNINGS.....	3
ELECTRICAL PICTORIAL	4
OPERATING INSTRUCTIONS.....	5
MAINTENANCE GUIDE.....	6
SEMI-ANNUAL INSPECTION	9
INSPECTION AND LOCATION OF DECALS.....	9
SLIDER ASSEMBLY	10, 11, 12
MAIN FRAME ASSEMBLY	13
LIFTING CHAIN ASSEMBLY.....	15
ALUMINUM PLATFORM ASSEMBLY	16
PLATFORM CHAIN ASSEMBLY	17
CYLINDER HOUSING COVER.....	17
SPRING ASSEMBLY	18
DAMPER ASSEMBLY	18
TROUBLESHOOTING GUIDE.....	19-22

FOR YOUR RECORDS

Model No. _____ Date Purchased _____

Serial No. _____

NOTE: When Ordering Parts Be Sure To Include This Information!

Your Thieman Tailgate is constructed of top quality material and is warranted to be free from defects in material and workmanship under normal use. With routine maintenance and proper operation this liftgate will provide long lasting service and dependability.

PARTS ORDERING PROCEDURE

When ordering parts, please include all the information asked for below. If this information is not available, a photo of the required part may help Thieman identify and deliver the needed part to you.

THE FOLLOWING INFORMATION MUST BE INCLUDED:

1. Serial Number – Thieman TVL liftgate serial numbers can be found on the tag located on the inner or outer side of the curb side frame rail.
2. Model Number and Capacity.
3. Platform Size and Material – Steel or Aluminum.
4. Part number.
5. Description.
6. Quantity required.

WARNING!

The following list of warnings are to be read before operating the TVL series liftgate.

- + DO NOT operate this liftgate unless you have been properly instructed and have read and understood the Owner's Manual, operating instructions and all decals. Improper operation of this lift may result in serious personal injury and/or damage to the liftgate. If you have not received your Owner's Manual or are missing operating instructions, decals, etc., call Thieman at 419-586-7727.
- + The vehicle must be securely and properly braked on level ground before using the liftgate.
- + All protective covers and guards must be in place before operating the liftgate.
- + Before using liftgate, check for signs of improper maintenance or damage (unusual noises, vibrations, fails to operate freely, missing hardware, cracked welds...etc.) DO NOT use the lift if these are evident. Only an authorized Thieman distributor is qualified to do repairs on the liftgate. DO NOT attempt to do your own repairs or modify this liftgate. Altering this product will void all warranties and may damage the liftgate or even cause serious injury. If any repairs, adjustments, or maintenance not covered in this manual are required, contact your nearest Thieman distributor or call Thieman at 419-586-7727.
- + THIS IS NOT A PERSONNEL LIFT. Because of the pinch point between the platform and the truck, fall hazards, unstable loads, etc., riding the lift may cause severe personal injury or death. ALWAYS stay clear of the liftgate when in operation. Do NOT ride the liftgate.
- + This liftgate is intended for the use of loading and unloading cargo only, it is not to be used for anything other than this.
- + DO NOT OVERLOAD THE LIFTGATE. Each liftgate has a specific maximum capacity for lifting and lowering. The standard maximum rated capacities of the TVL series liftgates differs with each model as follows:

TVL125-1250 lbs. Maximum Load

TVL16-1600 lbs. Maximum Load

TVL 20-2000 lbs. Maximum Load

NOTE: Special options can lower the maximum rated capacities below those shown above. Be certain you know what the maximum rated capacity is for your particular liftgate.

- + NEVER off-center the load on the platform, from side to side or away from truck as this may overload the liftgate. The center of weight of the load should NEVER be placed beyond the center of the platform load surface, away from truck. Loads should be placed close to platform edge nearest truck. See figure 1.
- + NEVER allow any part of the load to extend beyond the edges of the platform.
- + NEVER lift or lower unstable loads.
- + NEVER operate liftgate if platform load surface is slippery.
- + Make certain that the area below the platform is clear before and at all times during operation of the liftgate.
- + Load and unload the platform from the rear and not from the side of the platform. Never remove the platform support chains to load or unload the platform.
- + Never operate lift trucks on or over any part of the platform.
- + Follow the maintenance guide as outlined in this manual.
- + NEVER move vehicle unless platform is properly stowed and power is off. Locking cams must be properly pinned before transit.

THERMAL DATA: To avoid overheating the motor do not operate this unit for more than 13 cycles/10 minutes with the maximum load. The motor then must be allowed to completely cool down to ambient temperature before cycling the lift again. This unit also has a 20% duty cycle, which means the liftgate can be cycled no more than 4 cycles/10 minutes constantly with a maximum load.

WARNING: POSITION LOADS PROPERLY ON PLATFORM

NEVER off-center the load on the platform, from side to side or away from truck as this may overload the liftgate. The center of weight of the load should NEVER be placed beyond the center of the platform load surface, away from truck. Loads should be placed close to the platform edge nearest truck. If a load is not uniformly distributed, then the heaviest portion should be closest to the edge of the platform nearest the truck. NEVER allow any part of the load to extend beyond the edges of the platform.



WARNING

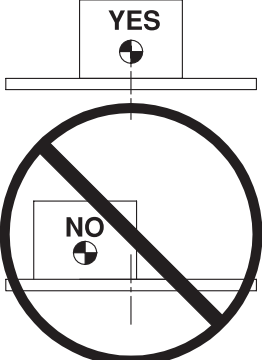

DO NOT OFF CENTER LOAD
(side to side)

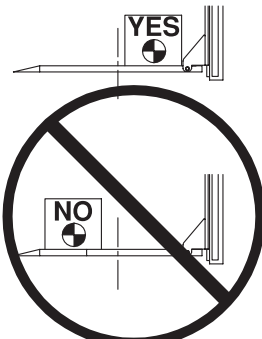

DO NOT OFF CENTER LOAD
(away from truck)

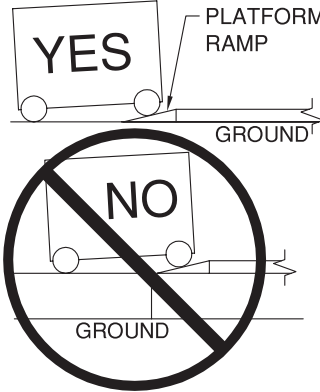

DO NOT place load on
platform ramp with platform
off ground

FIG. 1

ELECTRICAL PICTORIAL

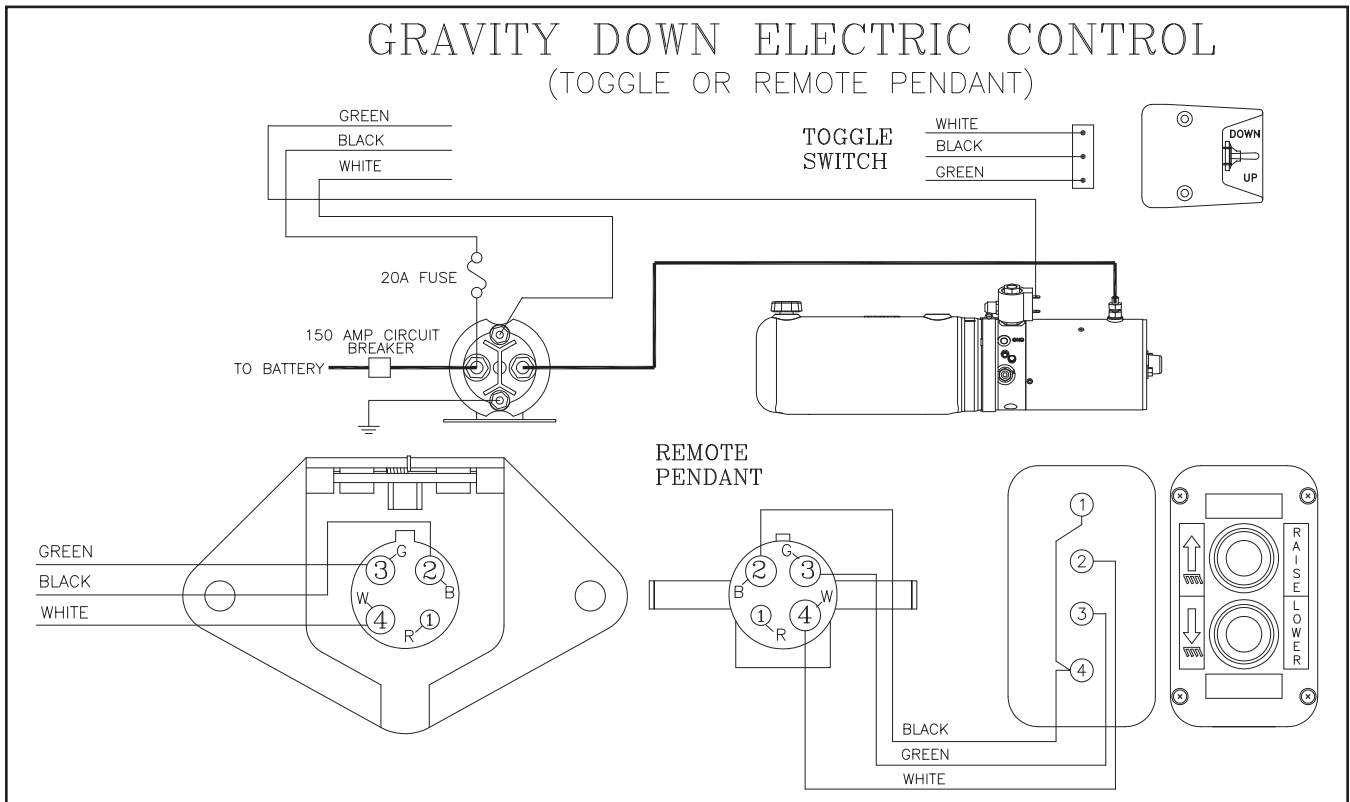

OPERATING INSTRUCTIONS

Caution

Be sure to operate liftgate at a safe distance and never improperly load platform as this may cause personal injury or damage to the liftgate.

OPENING OF PLATFORM

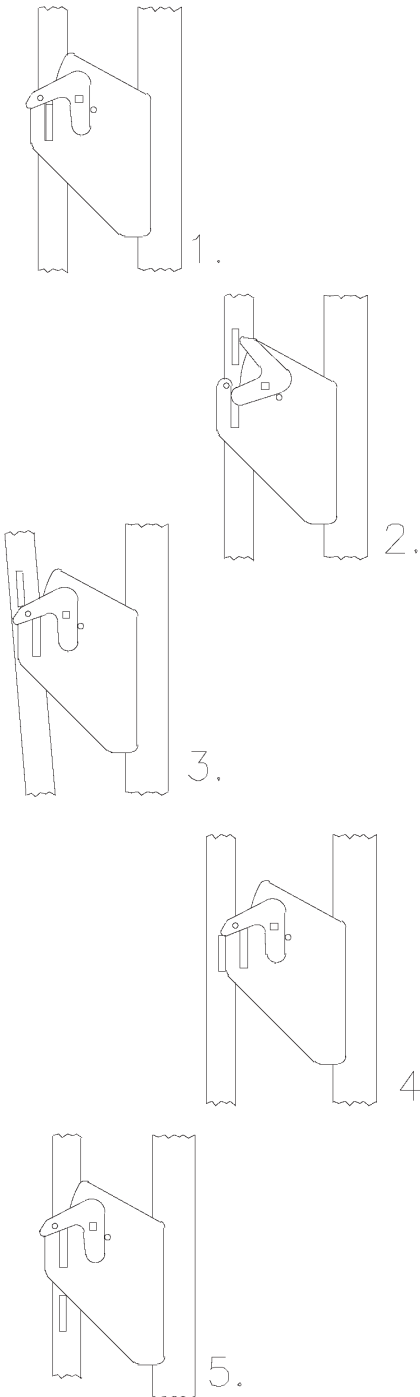

1. Remove latch pins and raise platform until it is completely out of the resting plates. Lower platform so guide plates ride over cam and is below resting plate. See illustrations.
2. Lower platform to a comfortable height for unfolding. Unfold the platform manually to the horizontal position.

LOADING AND UNLOADING

3. Raise or lower platform to the desired level for loading or unloading.

CLOSING OF PLATFORM

4. Fold platform up manually and raise until guide plates raise locking cam and are free to drop into resting plates.

LIFTGATE TRANSIT

5. Lower platform until guide plates are in resting plates completely. Push latch pins in hole through resting plate and cam to secure platform.

MAINTENANCE GUIDE

The following inspection and maintenance operations should be performed at the recommended intervals or anytime the liftgate shows signs of abuse, and improper or abnormal operation.

MONTHLY INSPECTION AND MAINTENANCE

Operate the liftgate throughout its entire operational cycle and check the following:

1. Check that there are no unusual noises or vibrations.
2. Check that the platform is level front to back and side to side when raised to bed height. If front to back adjustments are necessary, this can be done by adjusting side nuts(A) on U-bolt(B) on platform block(C). See figure 2. If side to side adjustments are necessary, this can be done by adjusting nuts(D), nylon insert locknuts(E), and lockwashers(F) on tension rods(G) on anchor bracket(H). See figure 2.

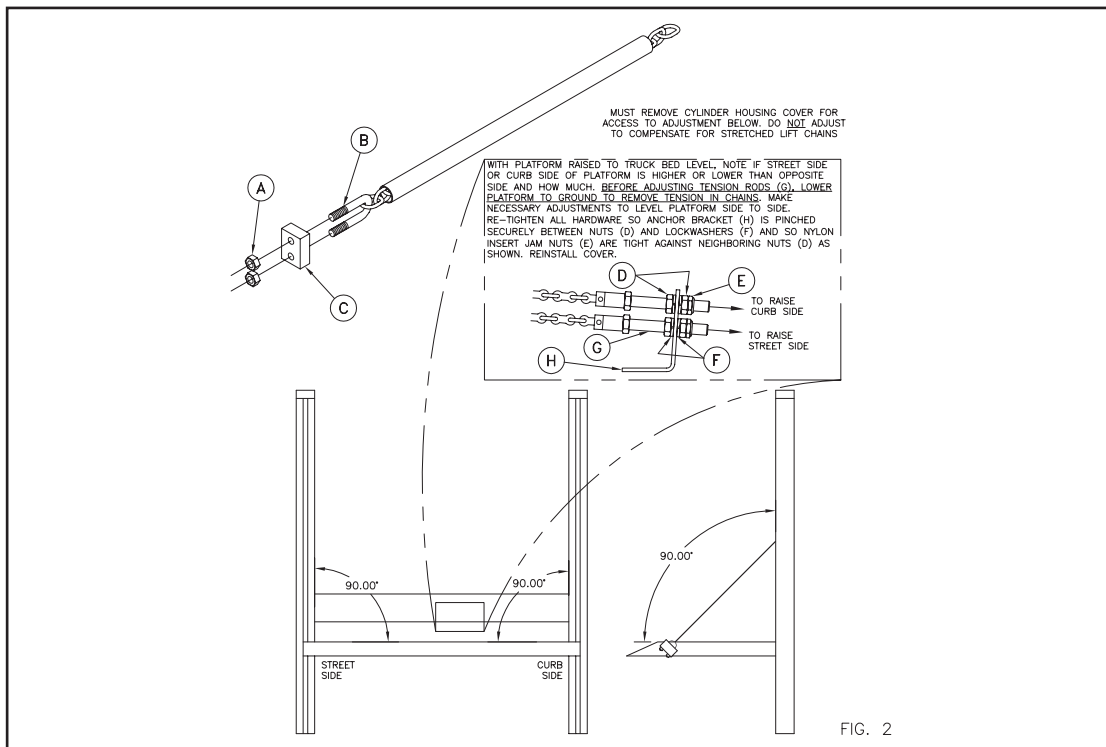

3. Check for apparent damage to the liftgate such as bent or distorted members, any cracked welds, which may have resulted from overloading or abuse.
4. Check for excessive wear or missing or deformed retainers in the following areas:
 - A. Roller and pin assemblies
 - B. Platform and hinge pins and pivot plates
 - C. Platform support chains and chain anchor points
 - D. Lift chains—replace if stretched or non-flexible
5. Check that all platform pivot pins are in place and retained by their proper retainers. The street side platform pivot pin (Adjusting Bracket) is bolted to the slider pivot with a 3/8 bolt. There is a formed retainer welded to the street side of the platform, which wraps around the slotted plate of the Adjusting Bracket in the stored position and holds the street side platform pivot pin in the platform pivot. The curb side platform pivot pin (Pin Retainer) is bolted to the slider pivot with a 3/8 bolt. There is a Stop, which is bolted to the curb side of the platform with two 1/4 inch screws which holds the curb side platform pivot pin in the platform pivot.
6. Check that all protective covers and guards are properly in place and secured.
7. Check for oil leaks in these areas:
 - A. Lift cylinder
 - B. Hydraulic hose—replace if it shows signs of wear or cracking
 - C. Hydraulic fittings—tighten or replace as may be required to stop leakage.

8. Check the oil level in the hydraulic reservoir located in the cylinder housing. With the platform open and at ground level, the oil should be within .50" from the top of the reservoir. See chart below.

HYDRAULIC FLUID CHART	
Temperature Range	Acceptable Fluids
-75 to 165°F	Exxon Unavis J-26
-20 to 130°F	Dexron III Exxon Superflo ATF Shell Spirax S3 ATF MD3
-50 to 80°F	Shell Aero Fluid 4 Mobil Aero HFA Exxon Unavis J-13 MIL H-5606

9. Check that all wiring and battery cable connections are tight and free of corrosion.
10. Lubrication of the TVL series liftgate should be as follows for all user conditions:

<u>Area of Tailgate</u>	<u>Type of Lubrication</u>	<u>*Frequency</u>
Slider Rails	SAE 10 to 20 oil	50 cycles
Lift Chain	SAE 10 to 20 oil	100 cycles
Chain Anchor Links	SAE 10 to 20 oil	100 cycles
Locking Cams	SAE 10 to 20 oil	100 cycles

*Note: TVL models which are used less than 50 cycles per week must be lubricated in the areas listed above no less than once a week. Once lubricated, operate the liftgate up and down through one complete cycle to spread lubricant evenly.

11. Check the pump relief pressure and also the motor amperage at this pressure. These should be as follows:

Model	Max Amp Draw	Relief Pressure (psi)
TVL 125/16/20	165	3000

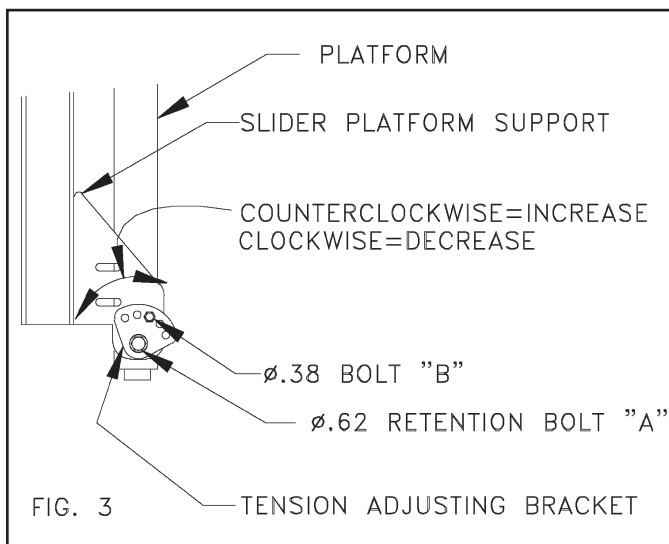

12. Torsion bar adjustment (See figure 3).
- Place platform in stowed (vertical) position.
 - Remove .62" diameter bolt (A) from center of tension adjusting bracket.
 - Place .50" square breaker bar in the square hole of the adjusting bracket pin.
 - Turn breaker bar clockwise to relieve tension on .38" diameter bolt (B) and remove it from the bracket.
 - To increase tension, rotate bracket counterclockwise until desired tension is reached. Line up hole in bracket to hole in slider platform support and replace bolt (B).

13. Set adjustment angles on either side of liftgate to hold platform vertical such that the stow bars on platform are aligned with the resting plate slots. Inspect alignment with stow bars raised completely out of resting plate slots (See figure 4A). If they are out of alignment, put the platform in the stored position. Raise platform slightly, so that stow bars are not sitting on the bottom of the resting plate slot, so there is tension in chains (See figure 4B). Then, loosen screws on the adjustment angles and move angles so they are tight against the vertical platform. Once angles are adjusted, tighten screws. Be sure to do this for both sides. Repeat inspection of stow bar alignment and readjust if necessary. Failure to keep stow bars aligned with resting plate slots can result in excessive wear of stow bars and resting plates.

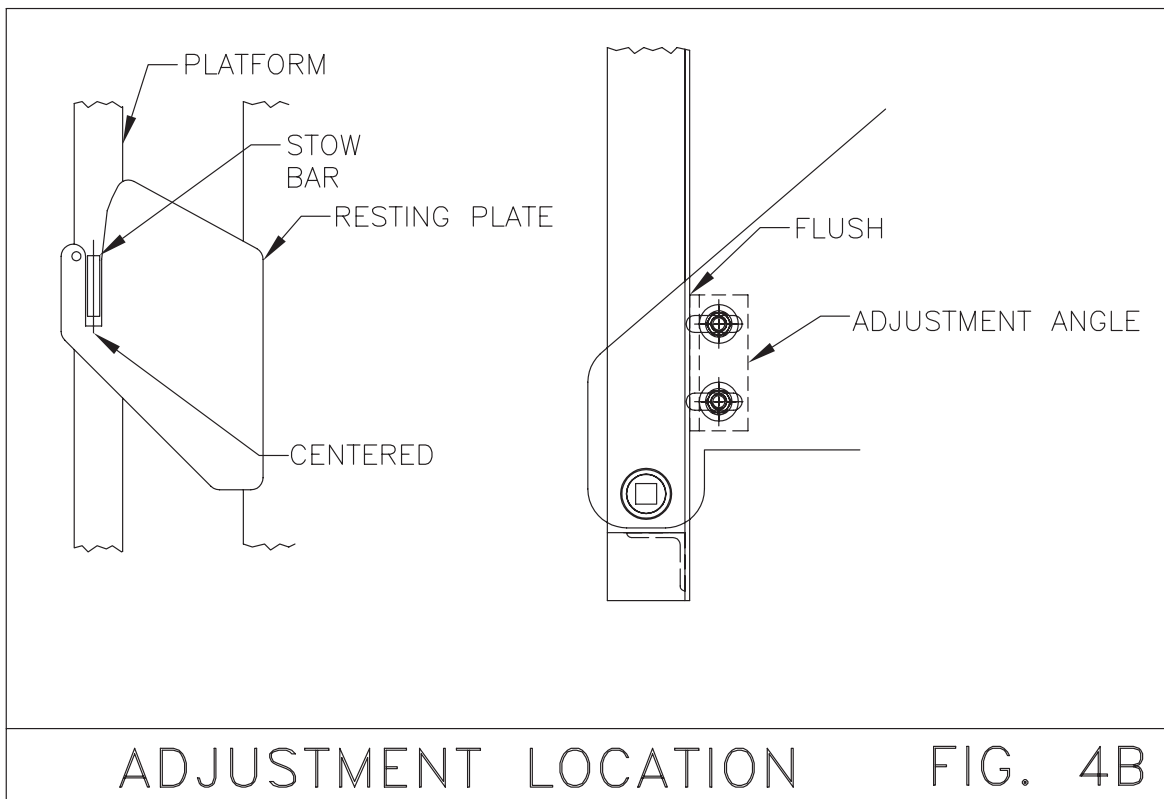
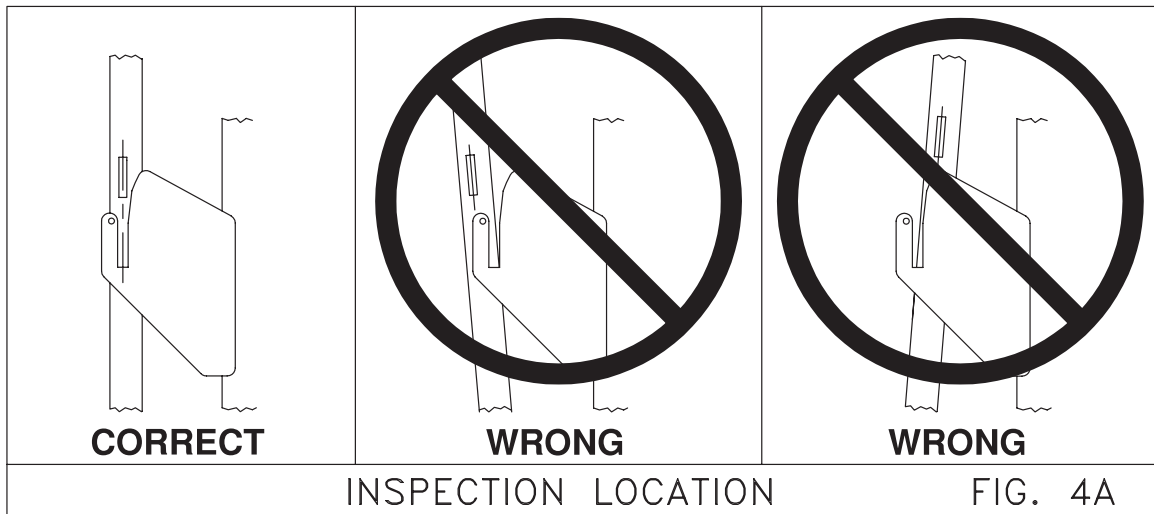

Semi Annual Inspection

1. Perform the procedures outlined in the "Monthly Inspection and Maintenance."
2. Inspect the pump motor by:
 - A. Disconnecting battery cable
 - B. Remove motor end cover
 - C. Examine the armature brushes for wear. (Brushes should be replaced if they are less than .12" long).
 - D. Clean all residue out from inside of the motor housing.
 - E. Apply several drops of light weight machine oil to the armature shaft bearing in the motor end cover and reassemble the motor end cover.
3. If the hydraulic oil in the reservoir is dirty:
 - A. Unfold the platform and lower completely to the ground so the cylinder is fully retracted.
 - B. Drain the oil from the hydraulic system and flush the entire system.
 - C. Remove the reservoir from the pump and clean suction line filter. Also clean out any contaminants from the reservoir. Remount the reservoir when completed.
 - D. Replace the oil as outlined in Section 8 under Monthly Maintenance and Inspection.

INSPECTION AND LOCATION OF DECALS

Inspect all decals listed below to be certain they are in the proper location and they are legible.

ALL DECALS MUST BE IN PLACE AND LEGIBLE OR ALL WARRANTIES ARE VOID!

Item	Part Name	Part Number
1	Warning Decal-center load	4682
2	Fast Idle Decal	4650150
3	Danger Decal-no riding	4609
4	Operating Decal	4650780
5	Capacity Decal 1250#	4650060
5	Capacity Decal 1600#	4650750
6	Caution Decal-pinch point	4650790
7	Caution Decal-cover	4650760
8	Caution Decal-working area	4650770
9	Reflector (3)	5705
10	Thieman Nameplate	4650801
11	Toggle Switch Decal (1)	4650820
12	Wiring Decal	4617
13	Warning Decal-high pressure	4620
14	Lubrication Instruction Decal	4662
15	Lube Location Decal (4)	4663
16	Urgent Warning Decal	4681

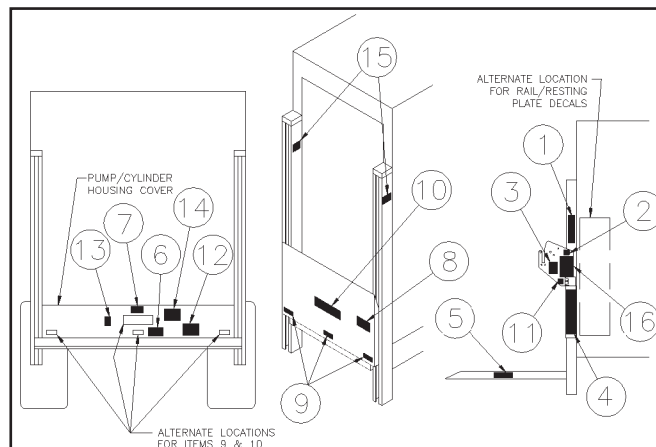

TVL125/16 ROLLER SLIDERS

Item	Part Number	Description	Qty
1	31753-001	Slider Assembly LH (Includes Item 3 and Items 5 thru 11)	1
1	31753-003	Slider Assembly LH w/Spring (Includes Item 3 and Items 5 thru 11)	1
2	31753-002	Slider Assembly RH (Includes Item 4 and Items 5 thru 11)	1
2	31753-004	Slider Assembly RH w/Spring (Includes Item 4 and Items 5 thru 11)	1
3	31752-001	LH Slider Weldment	1
3	31752-003	LH Slider Weldment w/Spring	1
4	31752-002	RH Slider Weldment	1
4	31752-004	RH Slider Weldment w/Spring	1
5	5506	Roller Assembly	4
6	8120396	Flatwasher .50	8
7	8103-011	Locknut .50-20	8
8	5776	Wear Pad	8
9	8109-015	Screw .25-20 x 2.75	4
10	8120386	Flatwasher .25	8
11	8103-019	Locknut .25-20	4
12	5088	Lift Chain Pin	2
13	2013	Adjustment Angle	2
14	8120388	.38 Flatwasher	8
15	8180126	.38-16 x 1.50 Screw	4
16	8120382	.38 Lockwasher	4
17	8120377	.38-16 Nut	4
18	8106-016	.38 Int/Ext Tooth Lockwasher	8

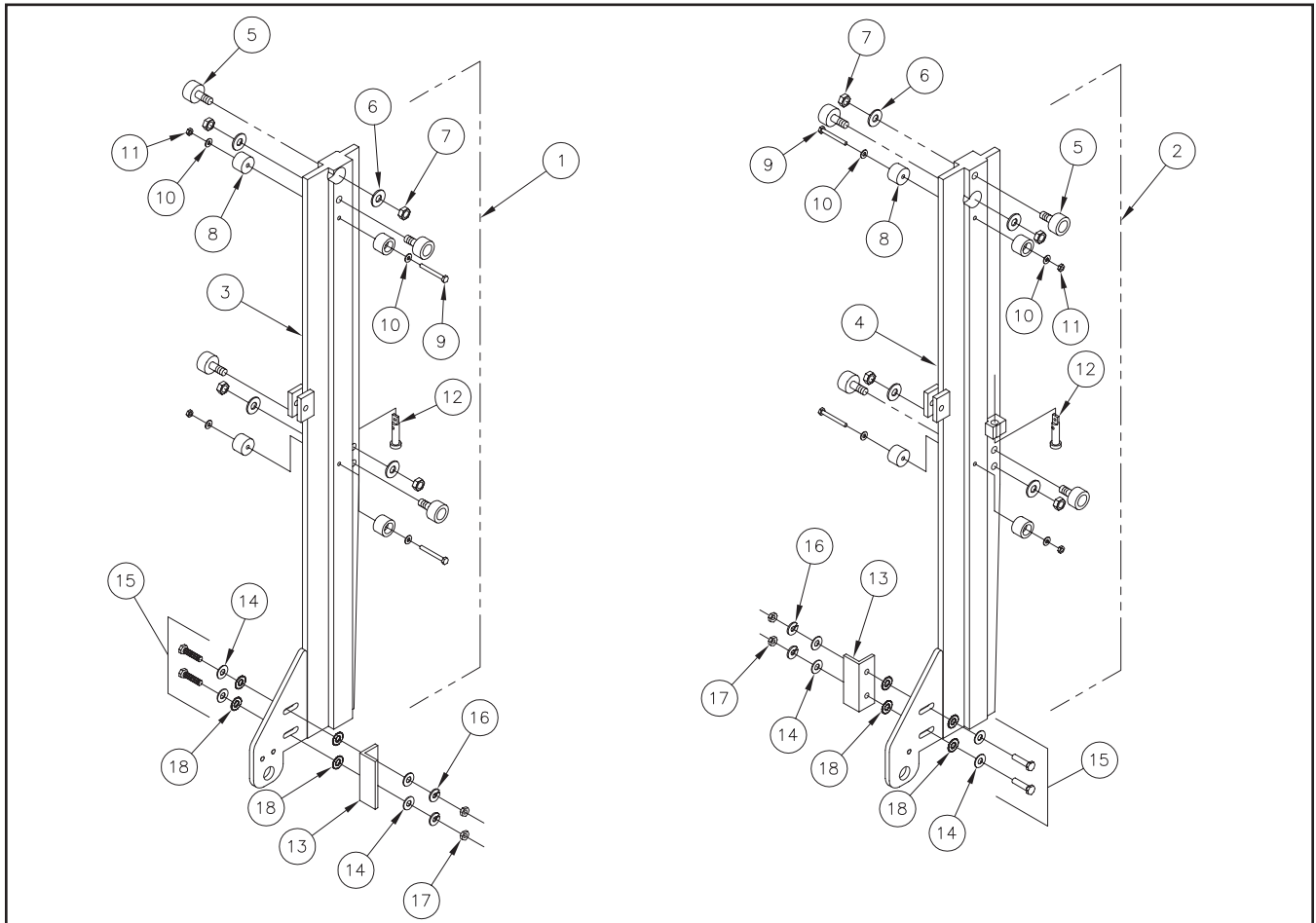

TVL HD ROLLER SLIDERS

Item	Part Number	Description	Qty
1	31586-001	HD Slider Assembly LH w/Spring (Includes Item 3 and Items 5 Thru 11)	1
1	31586-003	HD Slider Assembly LH (Includes Item 3 and Items 5 thru 11)	1
*1	31586-005	HD Slider Assembly LH w/Spring (Includes Item 3 and Items 5 thru 11)	1
*1	31586-007	HD Slider Assembly LH (Includes Item 3 and Items 5 thru 11)	1
2	31586-002	HD Slider Assembly RH w/Spring (Includes Item 4 and Items 5 thru 11)	1
2	31586-004	HD Slider Assembly RH (Includes Item 4 and Items 5 thru 11)	1
*2	31586-006	HD Slider Assembly RH w/Spring (Includes Item 4 and Items 5 thru 11)	1
*2	31586-008	HD Slider Assembly RH (Includes Item 4 and Items 5 thru 11)	1
3	31585-001	LH HD Slider Weldment w/Spring	1
3	31585-003	LH HD Slider Weldment	1
*3	31585-005	LH HD Slider Weldment w/Spring	1
*3	31585-007	LH HD Slider Weldment	1
4	31585-002	RH HD Slider Weldment w/Spring	1
4	31585-004	RH HD Slider Weldment	1
*4	31585-006	RH HD Slider Weldment w/Spring	1
*4	31585-008	RH HD Slider Weldment	1
5	5506	Roller Assembly	4
6	8120396	Flatwasher .50	8
7	8103-011	Locknut .50-20	8
8	5776	Wear Pad	8
9	8109-015	Screw .25-20 x 2.75	4
10	8120386	Flatwasher .25	8
11	8103-019	Locknut .25-20	4
12	5088	Lift Chain Pin	2
13	2013	Adjustment Angle	2
14	8120388	.38 Flatwasher	8
15	8180126	.38-16 x 1.50 Screw	4
16	8120382	.38 Lockwasher	4
17	8120377	.38-16 Nut	4
18	8106-016	.38 Int/Ext Tooth Lockwasher	8

*Denotes sliders with chain anchor near top of slider for use with deep platforms.

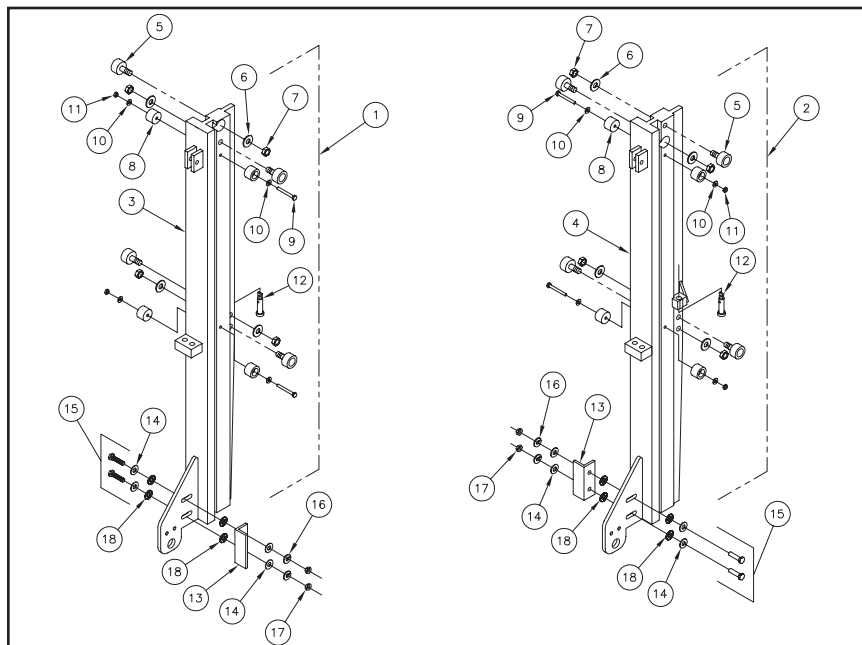

HD 2-PIECE PLATFORM SLIDERS

Item	Part Number	Description	Qty
1	31751-001	Slider Assembly LH (Includes Item 3 and Items 5 thru 11)	1
2	31751-002	Slider Assembly RH (Includes Item 4 and Items 5 thru 11)	1
3	31750-001	Slider Weldment LH	1
4	31750-002	Slider Weldment RH	1
5	5506	Roller Assembly	4
6	8120396	Flatwasher .50	8
7	8103-011	Locknut .50-20	8
8	5776	Wear Pad	8
9	8109-015	Screw .25-20 x 2.75	8
10	8120386	Flatwasher .25	8
11	8103-019	Locknut .25-20	4
12	5088	Lift Chain Pin	2
13	2013	Adjustment Angle	2
14	8120388	.38 Flatwasher	8
15	8180126	.38-16 x 1.50 Screw	4
16	8120382	.38 Lockwasher	4
17	8120377	.38-16 Nut	4
18	8106-016	.38 Int/Ext Tooth Lockwasher	8

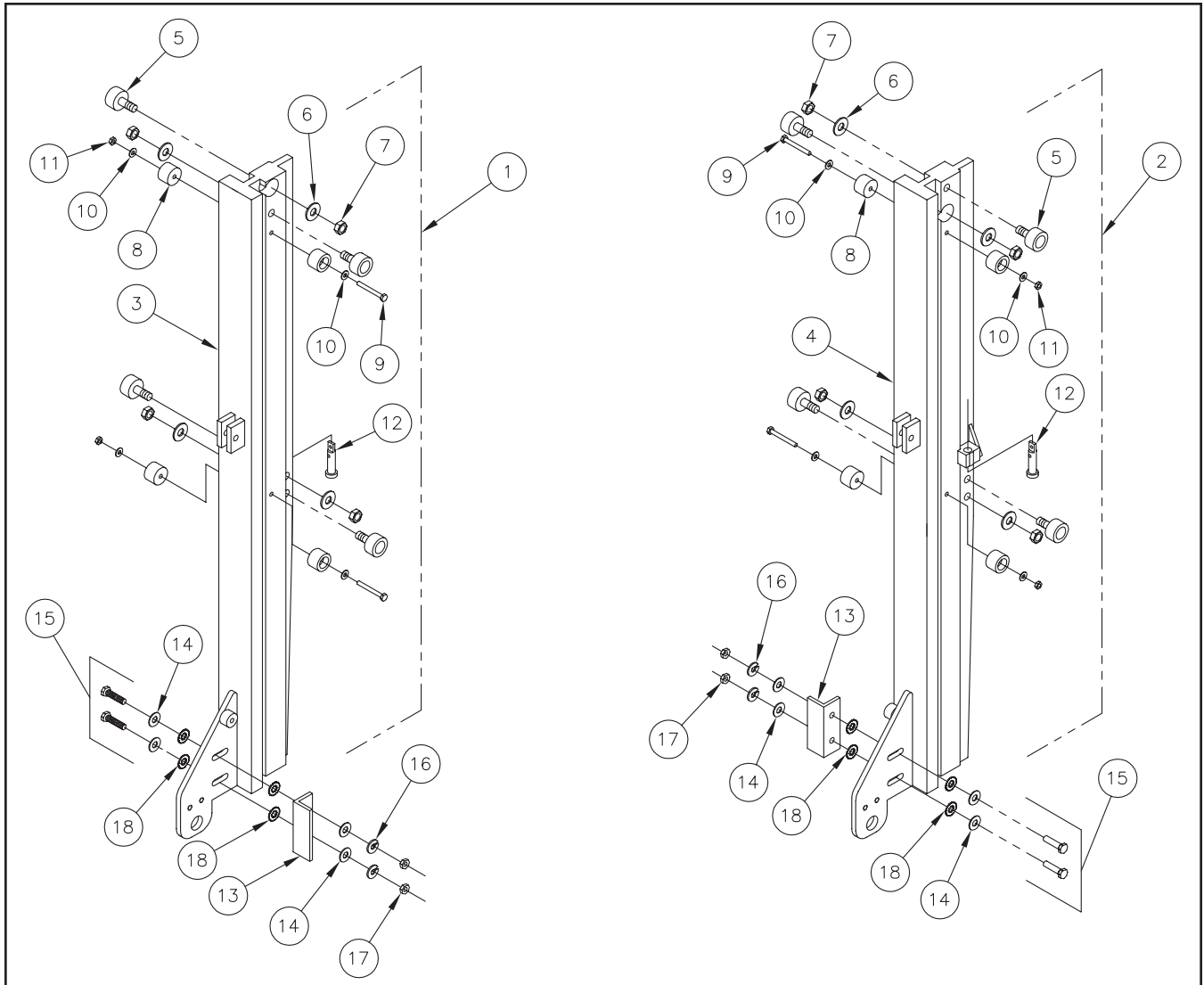

MAIN FRAME ASSEMBLY

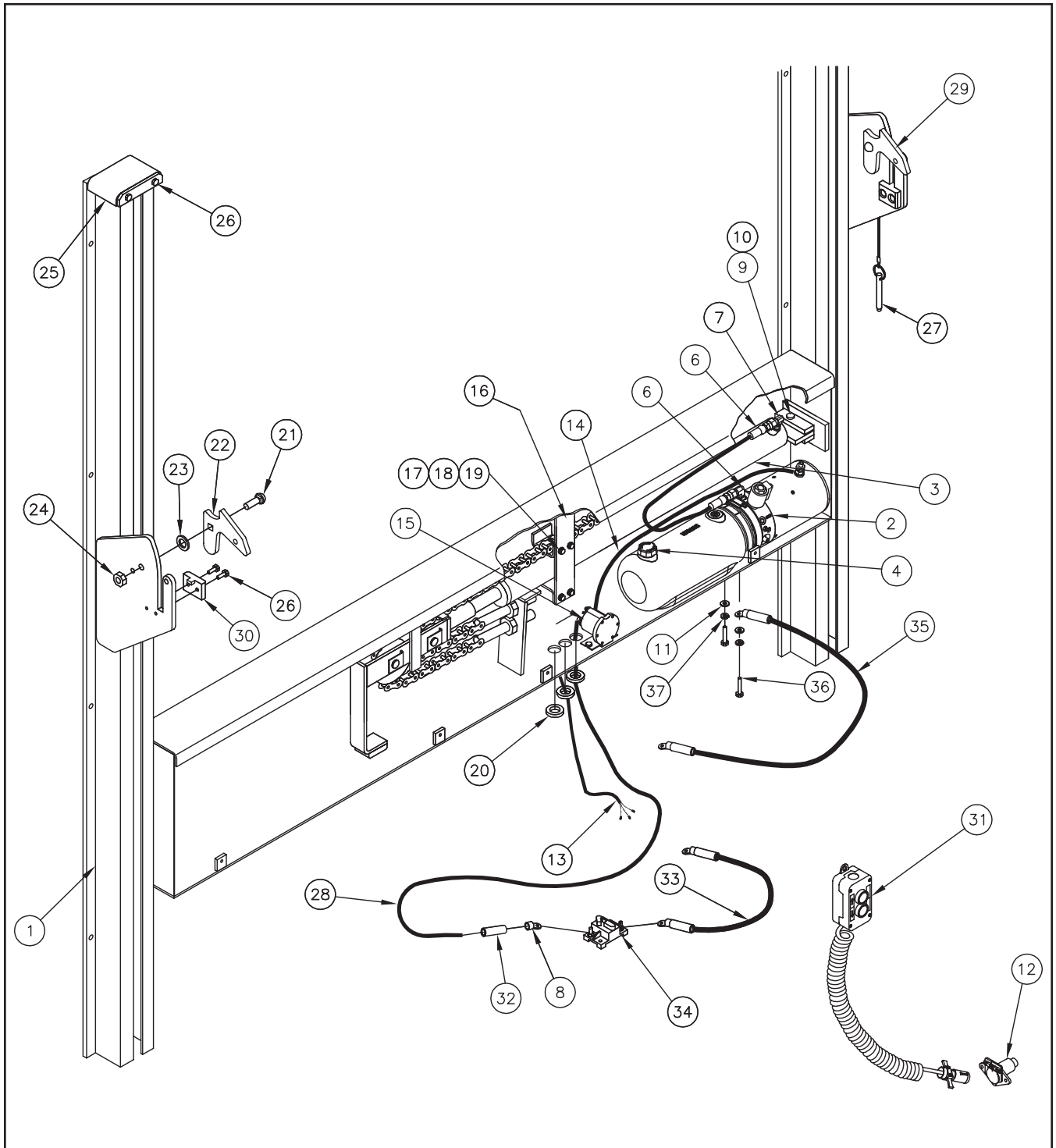

Item	Part Number	Description	Qty Per Model	
			125/16/20/20A	125A/16A/20/20A
1	31237-001	Main Frame 80, Std Platform (46"BH)		1
1	31237-002	Main Frame 80, Std Platform (56"BH)	1	
1	31237-003	Main Frame 80, Std Platform (37"BH)		1
1	31237-004	Main Frame 80, Deep Platform 72" & Up (46"BH)		1
1	31237-005	Main Frame 80, Deep Platform 72" & Up (56"BH)	1	
1	31237-006	Main Frame 80, Deep Platform 72" & Up (37"BH)		1
1	31237-007	Main Frame 85, Std Platform (46"BH)		1
1	31237-008	Main Frame 85, Std Platform (56"BH)	1	
1	31237-009	Main Frame 85, Std Platform (37"BH)		1
1	31237-010	Main Frame 85, Deep Platform 72" & Up (46"BH)		1
1	31237-011	Main Frame 85, Deep Platform 72" & Up (56"BH)	1	
1	31237-012	Main Frame 85, Deep Platform 72" & Up (37"BH)		1
1	31237-013	Main Frame 90, Std Platform (46"BH)		1
1	31237-014	Main Frame 90, Std Platform (56"BH)	1	
1	31237-015	Main Frame 90, Std Platform (37"BH)		1
1	31237-016	Main Frame 90, Deep Platform 72" & Up (46"BH)		1
1	31237-017	Main Frame 90, Deep Platform 72" & Up (56"BH)	1	
1	31237-018	Main Frame 90, Deep Platform 72" & Up (37"BH)		1
1	31237-019	Main Frame 95, Std Platform (46"BH)		1
1	31237-020	Main Frame 95, Std Platform (56"BH)	1	
1	31237-021	Main Frame 95, Std Platform (37"BH)		1
1	31237-022	Main Frame 95, Deep Platform 72" & Up (46"BH)		1
1	31237-023	Main Frame 95, Deep Platform 72" & Up (56"BH)	1	
1	31237-024	Main Frame 95, Deep Platform 72" & Up (37"BH)		1
1	31237-025	Main Frame 100, Std Platform (46"BH)		1
1	31237-026	Main Frame 100, Std Platform (56"BH)	1	
1	31237-027	Main Frame 100, Std Platform (37"BH)		1
1	31237-028	Main Frame 100, Deep Platform 72" & Up (46"BH)		1
1	31237-029	Main Frame 100, Deep Platform 72" & Up (56"BH)	1	
1	31237-030	Main Frame 100, Deep Platform 72" & Up (37"BH)		1
2	4473	Power Unit	1	1
3	42004	Cylinder	1	1
4	4420409	Breather Cap	1	1
5	4930-001	MJ-MAORB 90°	1	1
6	4951-002	Hose .25 x 12	1	1
7	4931-001	Restrictor MJ-MAORB 90°	1	1
8	4351	Cable Lug	1	1
9	8101-001	Clevis Pin	1	1
10	5700022	Hairpin Cotter	1	1
11	8120388	Flatwasher .38	2	2
12	4301342	Receptacle	1	1
13	4301290	Wire Harness	1	1
14	4318-002	Battery Cable	1	1
15	4477	Solenoid	1	1
16	31558	Cylinder Retainer Weld	1	1
17	8109-001	Screw .25 x 1	4	4
18	8106-002	Lockwasher .25	4	4
19	8103-003	Nut .25	4	4
20	5751	Grommet	3	3
21	8100-004	Carriage Bolt .5 x 1.5	2	2
22	27068-001	Locking Cam LH	1	1
23	8107-003	Flatwasher SS .50	2	2
24	8103-004	Locknut SS .50	2	2
25	31243	Sprocket Housing Weld	2	2
26	8109-002	Screw .25 x .75	10	10
27	3109140	Latch Cable Assembly	2	2
28	4300030	Battery Cable 25'	1	1
29	27068-002	Locking Cam RH	1	1
30	5791	Resting Plate Pad	2	2
31	4309	Pendant Control	1	1
32	4319-002	Heat Shrink	1	1
33	4318-001	Battery Cable #2 x 2'	1	1
34	4301770	Circuit Breaker	1	1
35	4318-003	Ground Cable #2 x 2'	1	1
36	8108-002	Screw .38 x 1.50	2	2
37	8106-001	Lockwasher-.38	2	2

LIFTING CHAIN ASSEMBLY

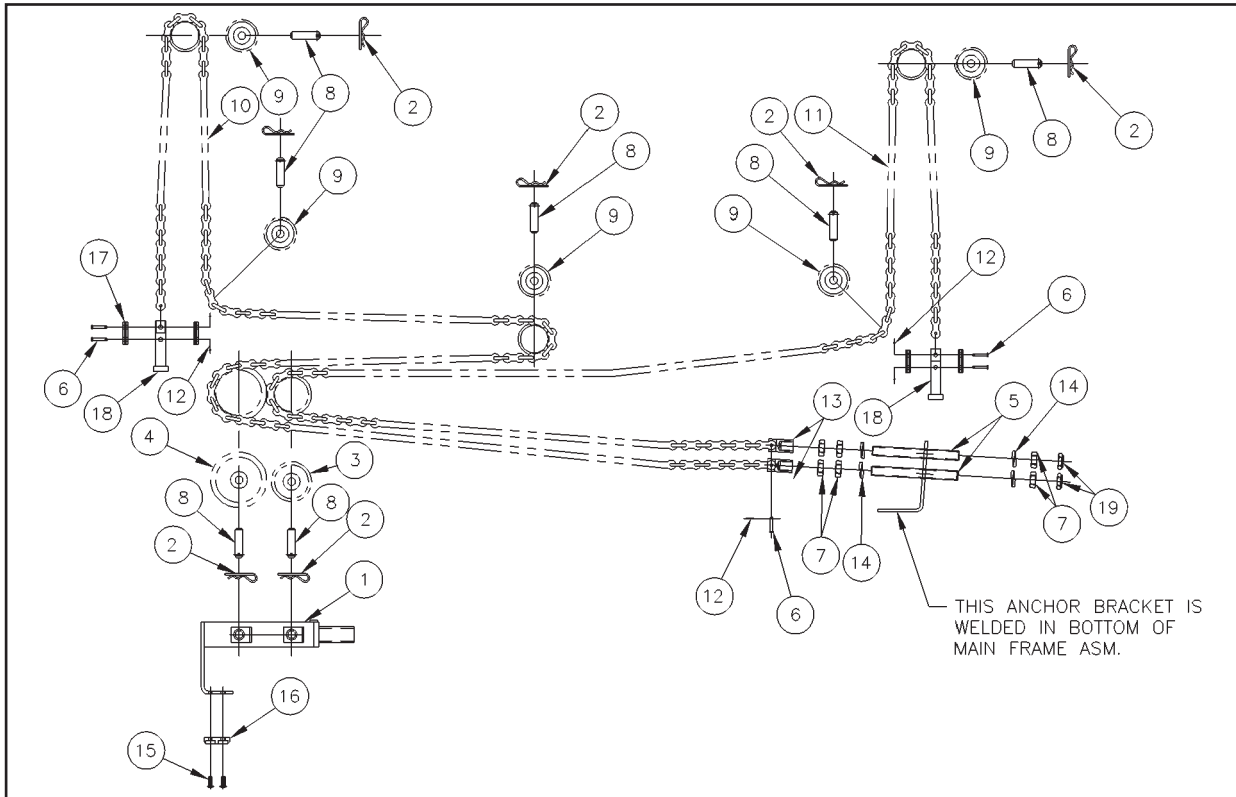

Item	Part Number	Description	Gate Model Qty.			
			125/16	125A/16A	20	20A
1	31528	Pusher Weld	1	1		
1	3109576	Pusher Weld			1	1
2	5700022	Hairpin Cotter	7	7	7	7
3	31213-002	3.25 Chain roller asm	1	1	1	1
4	31213-003	4.50 Chain roller asm	1	1	1	1
5	5084-001	Tension rod	2	2	2	2
6	2502100	Chain anchor pin	6	6	6	6
7	8219758	.75 Jam nut	6	6	6	6
8	5067	Pin	7	7	7	7
9	31213-001	2.63 Chain roller asm	5	5	5	5
10	4100-010	Chain SS 90 (56" BH)	1		1	
10	4100-011	Chain SS 95 (56" BH)	1		1	
10	4100-012	Chain SS 100 (56" BH)	1		1	
10	4100-013	Chain SS 90 (37", 46" BH)		1		1
10	4100-014	Chain SS 95 (37", 46" BH)		1		1
10	4100-015	Chain SS 100 (37", 46" BH)		1		1
10	4100-018	Chain SS 80 (56" BH)	1		1	
10	4100-019	Chain SS 80 (37", 46" BH)		1		1
11	4100-009	Chain CS All widths (56" BH)	1		1	
11	4100-011	Chain CS All widths (LB)		1		1
12	8116-001	Cotter pin	6	6	6	6
13	2350001	Chain anchor housing	2	2	2	2
14	8106-005	.75 Lockwasher	4	4	4	4
15	8449646	Self tapping screw	2	2	2	2
16	5703	Wear pad	1	1	1	1
17	4105	Chain Link	12	12	12	12
18	5088	Lift Chain Pin	2	2	2	2
19	8103-029	HEXJAM, Nylon Insert Locknut .75	2	2	2	2

ALUMINUM PLATFORM ASSEMBLY

Item	Part Number	Description	Qty
1	3407-001	7530 Platform	1
1	3407-002	7536 Platform	1
1	3407-003	7542 Platform	1
1	3407-004	7548 Platform	1
1	3407-005	7554 Platform	1
1	3407-006	7560 Platform	1
1	3407-007	7566 Platform	1
1	3407-008	8530 Platform	1
1	3407-009	8536 Platform	1
1	3407-010	8542 Platform	1
1	3407-011	8548 Platform	1
1	3407-012	8554 Platform	1
1	3407-013	8560 Platform	1
1	3407-014	8566 Platform*	1
1	3407-015	9030 Platform	1
1	3407-016	9036 Platform	1
1	3407-017	9042 Platform	1
1	3407-018	9048 Platform	1
1	3407-019	9054 Platform	1
1	3407-020	9060 Platform	1
1	3407-021	9066 Platform	1
1	3407-022	9530 Platform	1

*Requires one spring assembly.

Item	Part Number	Description	Qty
1	3407-023	9536 Platform	1
1	3407-024	9542 Platform	1
1	3407-025	9548 Platform	1
1	3407-026	9554 Platform	1
1	3407-027	9560 Platform*	1
1	3407-028	9566 Platform*	1
1	3407-029	8572 Platform*	1
1	3407-030	9072 Platform*	1
2	2329	Stop	1
3	8271713	Screw .62 x .75	1
4	8121574	Lockwasher .62	1
5	8130999	Flatwasher .62	1
6	8109-001	Screw .25 x 1	2
7	8120382	Lockwasher .38	2
8	3108980	Adjusting Bracket	1
9	3199	Pin Retainer	1
10	5101-001	Torsion Bar 85" Platform	1
10	5101-002	Torsion Bar 90" Platform	1
10	5101-003	Torsion Bar 95" Platform	1
10	5101-004	Torsion Bar 75" Platform	1
11	5504-001	Bushing	2
12	5504-005	Bushing	2
13	8180120	Screw .38 x .75	2
14	8106-002	Lockwasher .25	2

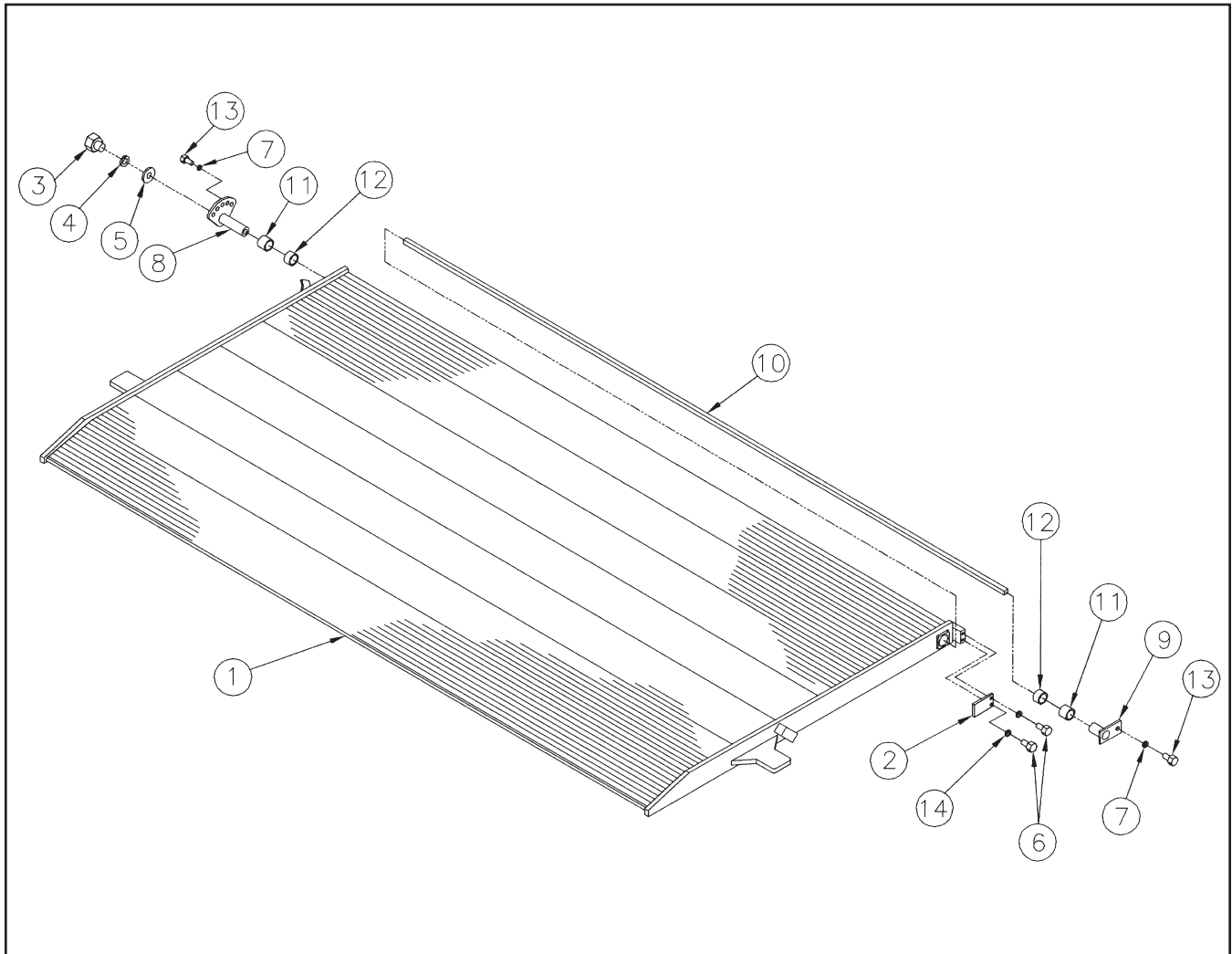

PLATFORM CHAIN ASSEMBLY

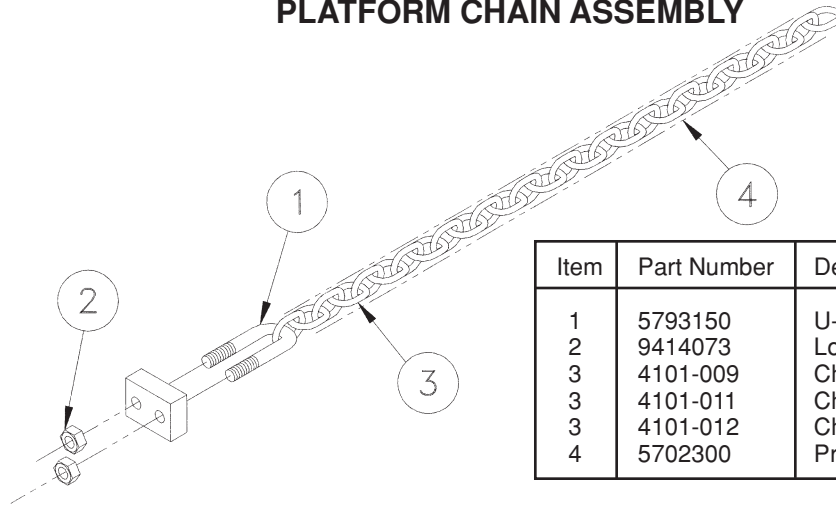

Item	Part Number	Description	Qty
1	5793150	U-Bolt	2
2	9414073	Locknut	4
3	4101-009	Chain 48", 54" Deep	2
3	4101-011	Chain 60", 66" Deep	2
3	4101-012	Chain 30", 36", 42" Deep	2
4	5702300	Protective Sleeve	2

HOUSING COVERS

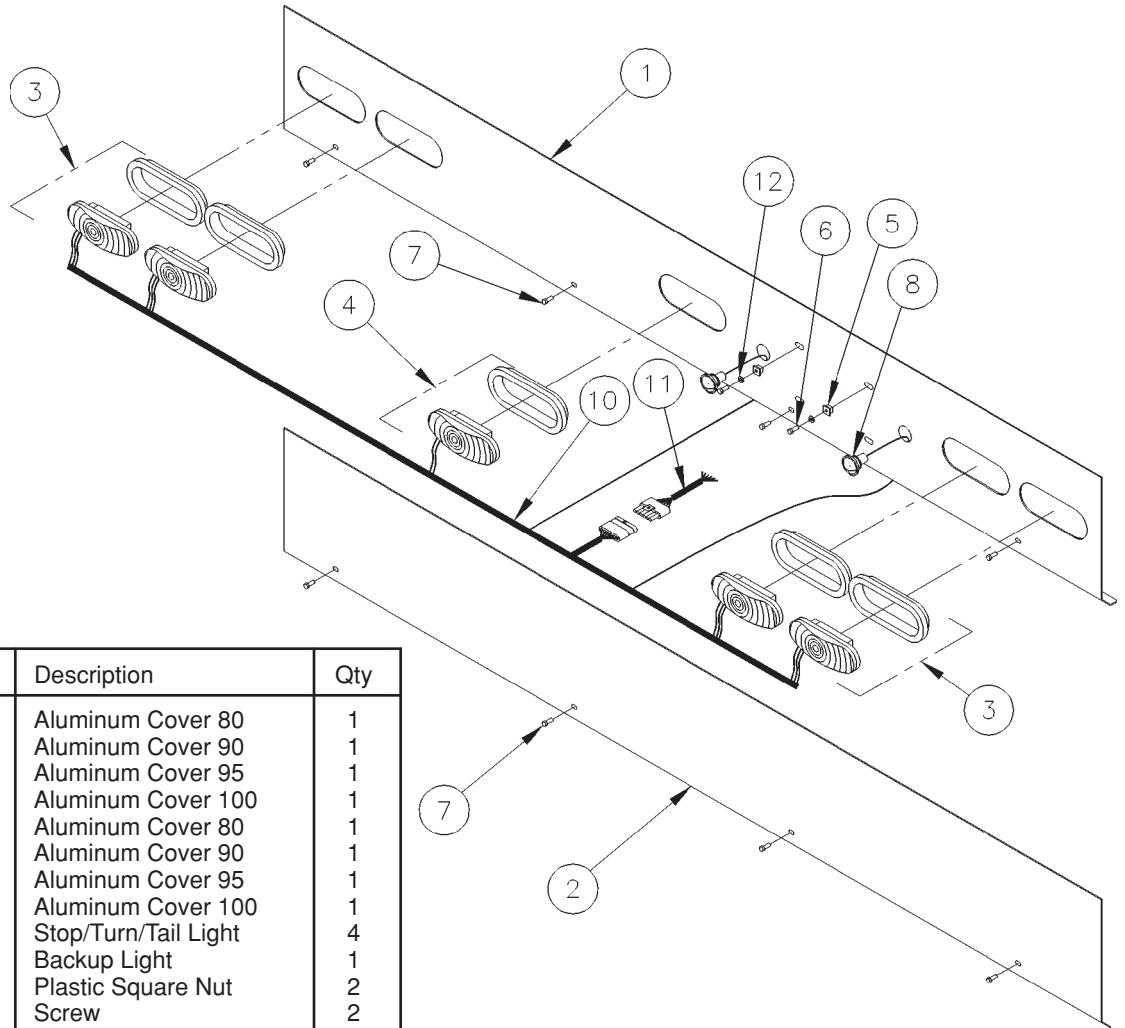

Item	Part Number	Description	Qty
1	2711412	Aluminum Cover 80	1
1	2711411	Aluminum Cover 90	1
1	2711413	Aluminum Cover 95	1
1	2711414	Aluminum Cover 100	1
2	27072-001	Aluminum Cover 80	1
2	27072-002	Aluminum Cover 90	1
2	27072-003	Aluminum Cover 95	1
2	27072-004	Aluminum Cover 100	1
3	4301320	Stop/Turn/Tail Light	4
4	4301330	Backup Light	1
5	5702270	Plastic Square Nut	2
6	5702280	Screw	2
7	5793010	Screw .25 x .62	4
8	4300550	License Plate Light	2
9	5792020	Gasket (not shown)	1
10	4308	Taillight Wiring Harness	1
11	4368	Taillight Wiring Harness	1
12	8107-007	Flat Washer	2

SPRING ASSEMBLY

Item	Part Number	Description	Qty
1	5793150	U-Bolt	1
2	9414073	Locknut .44	2
3	5101120	Spring	1

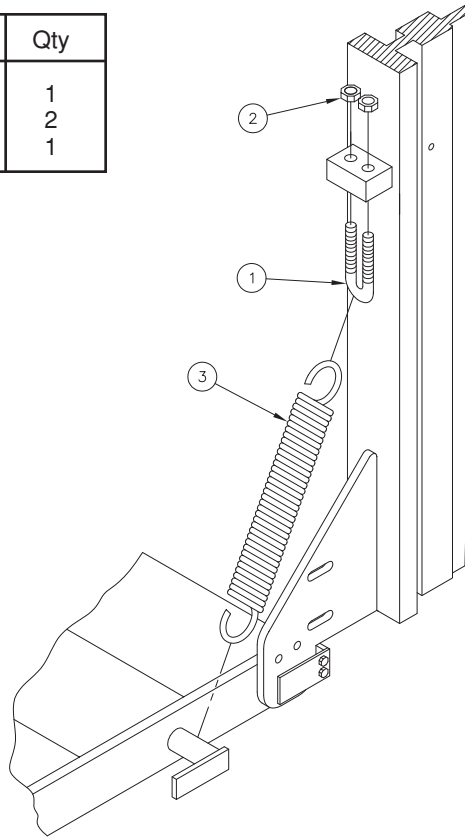

DAMPER ASSEMBLY

Item	Part Number	Description	Qty
1	5770	Hyd. Damper	1
2	8104-004	Screw .31-18 x 1.75	1
3	8104-012	Screw .31-18 x 1	1
4	8103-013	Locknut .31-18	2
5	8107-004	Flatwasher .31	2

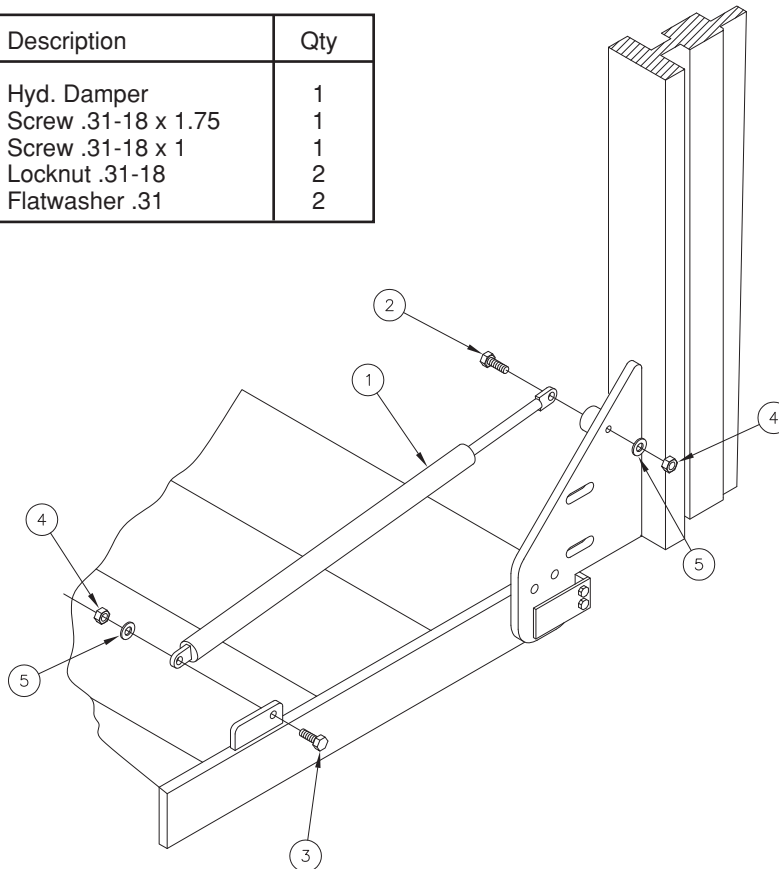

TROUBLESHOOTING GUIDE AATVL125/16ET

- Test Equipment:
1. 0-5000 psi pressure gauge
 2. DC voltmeter/ohm meter
 3. DC amp meter
 4. standard mechanics tools

Note: Please refer to the electrical diagrams and hose connection drawings in the liftgate's owners manual when troubleshooting. This guide is only for standard Thieman liftgates. Special liftgates with options other than those in the owner's manual will require special diagrams for troubleshooting. Read and understand this entire guide completely before doing any troubleshooting. Certain listed problems may be related to other problems listed so a comprehensive knowledge is required before proceeding.

1. Problem - Pump motor will not run in the raise mode

- Causes -
- a. Tripped circuit breaker
 - b. Blown 20A fuse
 - c. Defective or undercharged battery(ies)
 - d. Improper battery cable connection or improper ground connection
 - e. Defective or improperly wired raise switch
 - f. Defective or improperly wired solenoid start switch
 - g. Defective pump motor

- Corrections -
- a. Reset the circuit breaker located within 2ft of the liftgate supply battery(ies).
 - b. Replace 20A fuse.
 - c. The "at rest" voltage for the batteries without the engine running and under no load should be at least 12.5V. The minimum voltage between the motor stud and ground is 9V at maximum load conditions. If proper voltage is not present, charge or replace the batteries. The battery(ies) on the vehicle should be that which has a minimum 150 amp reserve capacity.
 - d. Trace battery and ground cable connections to locate improper connection(s). Make sure the ground cable is installed going from the pump mounting screws to bare metal on the truck frame. The ground cable from the batteries to the frame must be a heavy 2ga. cable and that is connected to bare metal on the frame. There must be 12.5V present at the large terminal on the motor start solenoid where the 2ga. cable from the batteries is connected. Replace any damaged cables and repair any bad connections.
 - e. Check for voltage on the black wire at the control switch. If no voltage is present the black wire from the motor start solenoid is loose or broken and needs repaired. If voltage is present then check for voltage at the white wire on the switch with the switch in the "RAISE" position. If no voltage is present, replace the switch.

- f. Check for voltage on the white wire at the motor start switch when the switch is activated. If no voltage exists the white wire is loose or broken between the switch and the motor start solenoid. Check that the ground wire on the start solenoid is connected properly and there are no bad connections. If there is voltage on the white wire and the coil does not energize or if there is no voltage present at the motor terminal then replace the start switch.
- g. With the switch activated in the “RAISE” position and the motor start solenoid is activated, check for voltage at the motor terminal. If voltage is present and the motor is not running, replace the motor.

2. Problem - Liftgate will not raise to bed with a load and the pump motor running

- Causes -
- a. Low hydraulic fluid
 - b. Overload condition
 - c. Improperly adjusted or defective main relief valve
 - d. Lift cylinder is bypassing, liftgate is drifting down
 - e. Broken hydraulic line
 - f. Clogged or disconnected suction line
 - g. Defective pump

- Corrections -
- a. Make sure the reservoir has the proper amount of fluid. Check for the fluid line through the plastic reservoir. The hydraulic fluid should be within 1/2” of the top of the reservoir with the liftgate in the lowered position. Fill with Dexron III automatic transmission fluid.
 - b. The power unit on the TVL125/16/20 is equipped with a lifting relief valve to prevent overloading of the liftgate. See relief setting in “Maintenance Guide” section of this manual.
 - c. See section “c” above for relief valve setting. Plumb a pressure gauge into the high pressure circuit of the liftgate. Remove all loads from the liftgate’s platform. Engage the “RAISE” switch until the liftgate is fully raised. Keep the “RAISE” switch engaged until the pump bypasses through the relief valve and note the pressure on the gauge at this time. If the rated relief pressure is not present during relief, adjust the high pressure relief valve setting as necessary. If the relief pressure is not attainable the relief valve must be cleaned and/or replaced or the pump is defective. See part “g” below.
 - d. If the liftgate will not raise with a load on the platform but empty is raising slowly or only partially, the cylinder may be bypassing. To check for a bypassing cylinder do the following. Lower the gate to the ground to relieve all pressure from the cylinder. Disconnect the cylinder from the pusher. Press the “RAISE” switch until the cylinder is fully extended and then for 15 to 20 seconds and watch for a steady stream of fluid coming out of the breather port. Replace or rebuild any cylinder with fluid coming out of the breather port, as this indicates fluid is bypassing the piston seals on the cylinder. Reconnect rebuilt or replaced cylinder and hoses as before.

- e. Broken or punctured hydraulic lines and fittings must be replaced with care to avoid injury from high pressure oil streams.
- f. With the liftgate at the ground, disconnect the power unit and remove the reservoir. Check to see if the suction tube is clogged or has fallen out of the pump base. Clean the screen or reattach the suction tube as required.
- g. If all else fails replace the power unit, it is probably worn out.

3. Problem - Liftgate will not lower

- Causes -
- a. Defective lowering solenoid coil or valve
 - b. Clogged or defective hydraulic lines, fittings or flow controls

- Corrections -
- a. With the "LOWER" switch engaged check for voltage on the green wire at the switch. If no voltage is present replace the switch. If voltage is present, with the "LOWER" switch engaged, check for voltage at the green wire on the lower solenoid valve coil terminal. If no voltage is present, the green wire from the "LOWER" switch is loose or broken and needs replaced. If there is voltage (minimum of 9.5 volts) and the valve is not opening to allow the gate to lower, either the lower coil is bad or the entire lower coil/valve assembly is bad. To check to see if the coil is defective, remove the green wire from the spade terminal on the lower coil and check for continuity between the spade terminal and the nut, which holds the coil on the valve stem. If continuity does not exist, replace the defective coil, otherwise replace the defective lower coil/valve assembly.
 - b. Remove any obstruction in the hoses, fittings or flow controls or replace any hose, fitting or flow control, which does not allow fluid to flow through freely.

4. Problem - Liftgate raises slowly - The raise speed of the TVL125/16 on a 56" bed height while empty at 70° F is approximately 18-20 seconds. The raise speed loaded for the same conditions is approximately 28-30 seconds.

- Causes -
- a. Overload condition
 - b. Cold weather
 - c. Partially blocked suction screen
 - d. Lift cylinder is bypassing
 - e. Improperly adjusted or defective raise relief valve
 - f. Low voltage and/or bad ground
 - g. Worn out pump

- Corrections -
- a. See section 2b
 - b. Refer to Owner's Manual for alternative oils to use for cold weather conditions.
 - c. Remove reservoir and clean or replace suction screen as necessary.
 - d. See section 2d
 - e. See section 2c

- f. The minimum voltage between the motor stud and ground is 9.5 volts at maximum load conditions. See section 1b and 1c.
- g. After all other corrections are performed it will be necessary to replace the pump.

5. Problem - Foamy oil flowing from reservoir breather

Causes - a. Air is present in the system

Corrections - a. This can occur if air enters the system if the fluid level is low, see problem 2, part a, or if the suction tube is disconnected, see problem 2, part f. Also air may enter through fittings, which are not tightened properly, so check for any leaks around fittings or hoses. Once the source of the air is determined, the cylinder must be bled of all air. Most air can be removed from the system by lowering the gate to the ground to relieve all pressure from the cylinder, unpinning the cylinder and cycling it back and forth several times from fully extended to fully retracted and allowing the pump to bypass through the relief valves for a few seconds in each direction.

6. Problem - Liftgate chatters when raising or lowering

Causes -

- a. Inadequate lubrication between sliders and rails
- b. Rail wear surfaces are dirty & contaminated
- c. Wear pads are worn down or embedded with contaminants
- d. Wear pad mounting screws are loose
- e. Platform chains are not in equal tension

Corrections -

- a. The rails should be lubricated on a regular basis. See the Owner's Manual for the type and frequency of lubrication. Use lubrication holes at the top of each rail for optimum lubrication dispersal **DO NOT USE GREASE!**
- b. If lubrication of the rails does not eliminate the chattering it may be necessary to completely clean the rails and slider wear pads. The sliders should be removed from the rails to thoroughly clean the rails and pads. Use a degreaser to accomplish this. Lubricate the pads and rails before reassembly. See step c.
- c. If the wear pads are worn down to the mounting screw heads or if they are embedded with contaminants it will be necessary to replace them at this time.
- d. Apply a thread locker loctite to the threads of the screws and tighten.
- e. Adjust the platform support chains so they are in equal tension.

If you have any questions or problems that are not covered in this guide please call Thieman's Engineering Department at 1 -800-524-5210.

