

SNOWPLOW OWNER'S MANUAL

Original Instructions



Automatixx[®]
ATTACHMENT SYSTEM



⚠ CAUTION

Read this document before operating or servicing snowplow.

This manual supersedes all editions with an earlier date.

SNOWPLOW OWNER DATA SHEET

Register your snowplow online at www.snowexproducts.com

Owner Name: _____

Date Purchased: _____

Dealer Name: _____ Phone: _____

Dealer Address: _____

Vehicle Model/Year: _____

Snowplow Model/Year: _____

Snowplow Type/Size: _____ Weight: _____ lb/kg

Ballast: No ___ Yes ___ Amount _____ lb/kg

Hydraulic Unit Serial Number: _____

Blade Serial Number (see label on back of blade): _____

TABLE OF CONTENTS

Snowplow Owner Data Sheet	3	POWER GRIP™ Hand-Held Control.....	31
Preface	7	Joystick Control.....	34
Safety	8	POWER PLOW & HDV Controls.....	38
Vehicle Application Information.....	16	POWER GRIP Hand-Held Control	38
Ballast Requirements	17	Joystick Control.....	42
Getting to Know Your Snowplow	18	FLEET FLEX Electrical System.....	47
Automatixx® System.....	18	SECURITY GUARD™ System.....	47
Blades	19	Smooth Stop/Soft Stop	52
A-Frame/T-Frame, Quadrant, and Headgear ..	19	SPEEDWING Blade Positions.....	53
SPEEDWING™, POWER PLOW™, and		POWER PLOW Blade Positions	55
Straight Blade Snowplows	19	HDV Blade Positions.....	57
HDV™ Snowplow	20	<i>Operating Your Snowplow, continued</i>	
Mount Kits	20	Snowplow Headlamp Check	60
STORM SEEKER™ Snowplow Headlamps.....	21	Hydraulic System	61
Cab Controls	22	Blade Drop Speed Adjustment.....	61
Straight Blade & SPEEDWING Snowplows ..	23	Transporting Snowplow.....	63
POWER PLOW & HDV Snowplows.....	24	Driving and Plowing on Snow and Ice	64
Accessories.....	25	Plowing Snow.....	65
Attaching Snowplow to Vehicle	27	General Instructions.....	65
Operating Your Snowplow.....	31	Hard Packed Snow	65
Straight Blade & SPEEDWING Controls.....	34	Deep Snow	65
		Clearing Driveways	67

TABLE OF CONTENTS

Clearing Parking Lots	68	Installing Hydraulic Fittings and Hoses.....	84
Parking with Snowplow Attached.....	68	Fuse Replacement	85
Towing a Disabled or Stuck Vehicle.....	68	Snowplow Vehicle Battery Best Practices	86
Detaching Snowplow from Vehicle and Storage	69	Vehicle.....	87
Maintenance	74	Recycle	87
Maintenance Videos	74	Blade Finish	87
Preseason Check.....	74	Emergency Parts/Tools.....	88
Postseason Maintenance.....	75	Troubleshooting.....	94
Maintenance and Adjustment.....	76	Snowplow Specifications & Accessories	89
Greasing HDV™ Pivot Pin Hinge.....	77	Snowplow Weights.....	89
Aiming Headlamp Beams.....	78	Snowplows & Accessories	90
Hydraulic System	80	Hydraulic Units: Pump Motor Specifications ...	92
Fluid Level.....	80		
Annual Fluid Change	81		
Hose or Fitting Replacement	83		

PREFACE

This manual has been prepared to acquaint you with the safety information, operation, and maintenance of your new SnowEx® snowplow. Please read this manual carefully and follow all recommendations.

Before installing a snowplow, make sure that your vehicle is equipped with all the vehicle manufacturer's and our required options for plowing. This will help ensure profitable and trouble-free operation of your snowplow. Keep this manual accessible. It is a handy reference in case minor service is required.

Your SnowEx snowplow hydraulic unit and blade both have a serial number. Record these serial numbers on the Snowplow Owner Data Sheet at the front of this manual for future reference.

When service is necessary, bring your snowplow to your local SnowEx outlet. They know your snowplow best and are interested in your complete satisfaction.

The illustrations found in this manual represent typical components. They may not match your exact installation.

Most of the information in this Owner's Manual applies to all Automatixx® snowplow applications. Differences among straight blade, SPEEDWING™, POWER PLOW™, or HDV™ applications are called out in the text or under separate headings, as applicable.

SAFETY

SAFETY DEFINITIONS

WARNING

Indicates a potentially hazardous situation that, if not avoided, could result in death or serious personal injury.

CAUTION

Indicates a potentially hazardous situation that, if not avoided, may result in minor or moderate injury. It may also be used to alert against unsafe practices.

NOTE: Indicates a situation or action that can lead to damage to your snowplow and vehicle or other property. Other useful information can also be described.

WARNING/CAUTION & INSTRUCTION LABELS

Become familiar with and inform users about the warning/caution and serial number labels on the back of the blade and the instruction label on the headgear.

NOTE: If labels are missing or cannot be read, see your sales outlet.

SAFETY

Instruction Labels – POWER PLOW™, SPEEDWING™, and Straight Blades

Attach/Detach Label

Warning/Caution Label

Multiple Pinch Points Warning Label



POWER PLOW & SPEEDWING Blades Only (both sides)

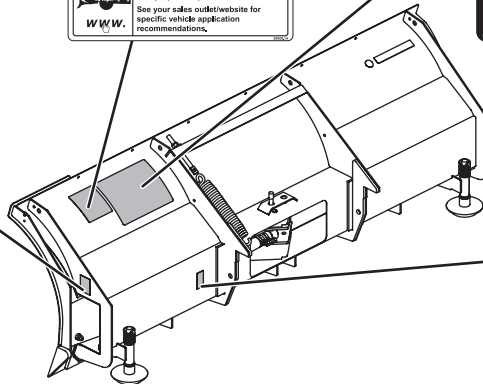

Foot Crush Hazard Warning Label

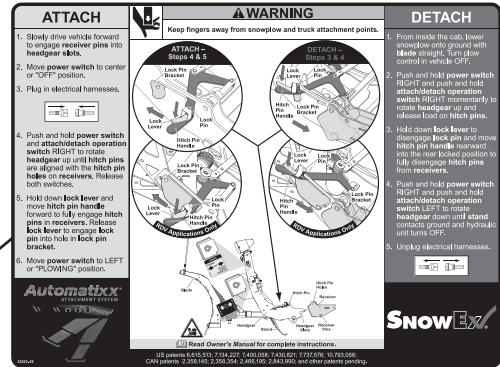

SAFETY

Instruction Labels – HDV™ Blade

Warning/Caution Label

WARNING



Blade could drop unexpectedly, crushing or trapping limbs. Lower blade when vehicle is parked.

Overloading could negatively affect vehicle handling. To avoid serious injury or death, do not exceed GVWR or GVWR including blade and ballast.

CAUTION





Read Owner's Manual before operating or servicing snowplow.

Transport speed should not exceed 45 mph (73 km/h). Further reduce speed under adverse travel conditions.

Plowing speed should not exceed 40 mph (64 km/h).

See your sales outlet/website for specific vehicle application recommendations.

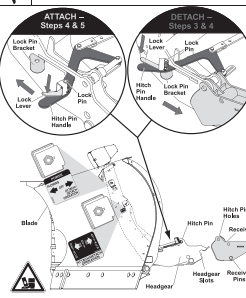
www.

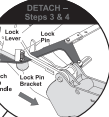
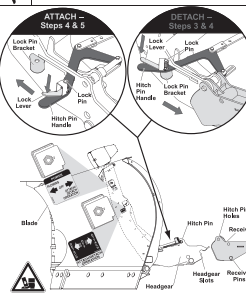
ATTACH	⚠ WARNING	DETACH
<ol style="list-style-type: none"> Slowly drive vehicle forward to engage receiver pins into headgear skids. Move power switch to center or "OFF" position. Plug in electrical harnesses. Push and hold power switch and attach/detach operation switch RIGHT to rotate headgear up until hitch pins are aligned with the hitch pin holes in receivers. Release both switches. Hold down lock lever and move hitch pin handle forward to fully engage hitch pins in receivers. Release lock lever to engage lock pin into hole in lock pin bracket. Move power switch to LEFT or "FLOWING" position. 	<p>Keep fingers away from snowplow and truck attachment points.</p> <div style="display: flex; justify-content: space-around;"> <div style="text-align: center;"> <p>ATTACH – Steps 4 & 5</p>  </div> <div style="text-align: center;"> <p>DETACH – Steps 2 & 4</p>  </div> </div>	<ol style="list-style-type: none"> From inside the cab, lower snowplow onto ground with blade in view position. Turn plow control in vehicle OFF. Push and hold power switch RIGHT and push and hold attach/detach operation switch RIGHT momentarily to rotate headgear up and release lock on hitch pins. Hold down lock lever to disengage lock pin and move hitch pin handle rearward into notch in end of slot to fully disengage hitch pins from receivers. Push and hold power switch LEFT and push and hold attach/detach operation switch LEFT to rotate headgear down and stacking stop contacts. Crane and hydraulic unit turns OFF. Unplug electrical harnesses. 
<p>Automatix ATTACHMENT SYSTEM</p> <p>Read Owner's Manual for complete instructions.</p> <p>US patents 6,618,145; 6,762,207; 6,860,858; 6,860,859; 6,927,476; 6,927,478; 6,927,480; 7,030,066; CAN patents 2,550,145; 2,550,354; 2,466,105; 2,464,995 and other pending patents.</p>		

Attach/Detach Label

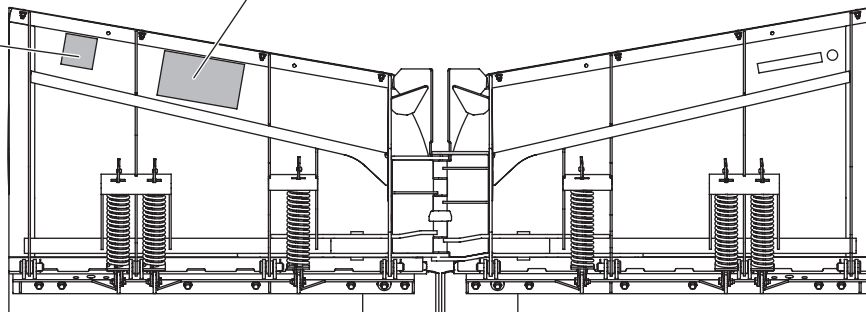

SAFETY

Serial Number Label

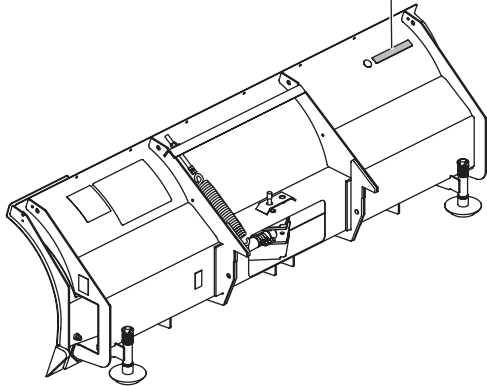
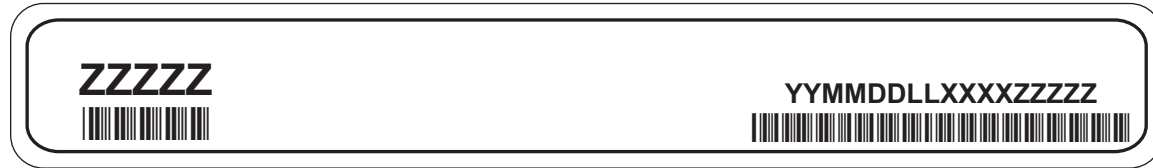

Code	Definition
YY	2-Digit Year
MM	2-Digit Month
DD	2-Digit Day
LL	2-Digit Location Code
XXXX	4-Digit Sequential Number
ZZZZZ	5- or 6-Digit Blade Assembly PN

SAFETY

SAFETY PRECAUTIONS

Improper installation and operation could cause personal injury and/or equipment and property damage. Read and understand labels and the Owner's Manual before installing, operating, or making adjustments.

WARNING

Lower the blade when the vehicle is parked. Temperature changes could change hydraulic pressure, causing the blade to drop unexpectedly or damaging hydraulic components. Failure to do this could result in serious personal injury.

WARNING



Do not exceed GVWR or GAWR including the blade and ballast. The rating label is found on the driver-side vehicle door cornerpost.

WARNING

Remove blade assembly before placing vehicle on hoist.

CAUTION

Read Owner's Manual before operating or servicing snowplow.

CAUTION

Transport speed should not exceed 45 mph (72 km/h). Further reduce speed under adverse travel conditions.

CAUTION

Plowing speed should not exceed 10 mph (16 km/h).

CAUTION

See your SnowEx® outlet for application recommendations.

SAFETY

HYDRAULIC SAFETY

⚠ WARNING



Hydraulic fluid under pressure can cause skin injection injury. If you are injured by hydraulic fluid, get medical attention immediately.

- Always inspect hydraulic components and hoses before using. Replace any damaged or worn parts immediately.
- If you suspect a hose leak, **DO NOT** use your hand to locate it. Use a piece of cardboard or wood.

FUSES

The SnowEx® electrical and hydraulic systems contain several automotive-style fuses. If a problem should occur and fuse replacement is necessary, the replacement fuse must be of the same type and amperage rating as the

original. Installing a fuse with a higher rating can damage the system and could start a fire. Fuse Replacement, including fuse ratings and locations, is located in the Maintenance section of this Owner's Manual.

PERSONAL SAFETY

- Remove ignition key and put the vehicle in **PARK** or in gear to prevent others from starting the vehicle during installation or service.
- Wear only snug-fitting clothing while working on your vehicle or snowplow.
- Do not wear jewelry or a necktie, and secure long hair.
- Wear safety goggles to protect your eyes from battery acid, gasoline, dirt, and dust.
- Avoid touching hot surfaces such as the engine, radiator, hoses, and exhaust pipes.
- Always have a fire extinguisher rated **BC** handy, for flammable liquids and electrical fires.

SAFETY

FIRE AND EXPLOSION

WARNING

Gasoline is highly flammable and gasoline vapor is explosive. Never smoke while working on vehicle. Keep all open flames away from gasoline tank and lines. Wipe up any spilled gasoline immediately.

Be careful when using gasoline. Do not use gasoline to clean parts. Store only in approved containers away from sources of heat or flame.

CELL PHONES

A driver's first responsibility is the safe operation of the vehicle. The most important thing you can do to prevent a crash is to avoid distractions and pay attention to the road. Wait until it is safe to operate mobile communication equipment such as cell phones, text messaging devices, pagers, or two-way radios.

VENTILATION

WARNING

Vehicle exhaust contains lethal fumes. Breathing these fumes, even in low concentrations, can cause death. Never operate a vehicle in an enclosed area without venting exhaust to the outside.

SAFETY

BATTERY SAFETY

CAUTION

Batteries normally produce explosive gases, which can cause personal injury. Therefore, do not allow flames, sparks, or lit tobacco to come near the battery. When charging or working near a battery, always cover your face and protect your eyes, and also provide ventilation.

- **Batteries contain sulfuric acid, which burns skin, eyes, and clothing.**
- **Disconnect the battery before removing or replacing any electrical components.**

NOISE

Airborne noise emission during use is below 70 dB(A) for the snowplow operator.

VIBRATION

Operating snowplow vibration does not exceed 2.5 m/s² to the hand–arm or 0.5 m/s² to the whole body.

VEHICLE APPLICATION INFORMATION

CAUTION

See your SnowEx® outlet/website for specific vehicle application recommendations before installation. The Power Match selection system has specific vehicle and snowplow requirements.

Vehicle application recommendations are based on the following:

- The vehicle with the snowplow installed must comply with applicable Federal Motor Vehicle Safety Standards (FMVSS).
- The vehicle with the snowplow installed must comply with the vehicle manufacturer's stated gross vehicle and axle weight ratings (found on the driver-side door cornerpost of the vehicle) and the front and rear weight distribution ratio. In some cases, rear ballast may be required to comply with these requirements. See "Ballast Requirements" in this section.
- The SnowEx Power Match selection system is based on available vehicle capacity for snowplow equipment on a representative vehicle equipped with options commonly used for plowing and with 300 lb (136 kg) of front seat occupant weight.
- Weights of front seat occupants can be adjusted above 300 lb (136 kg), but vehicle with snowplow must not exceed vehicle GVWR or GAWR.
- In some cases there may be additional limitations and requirements.
- Installation, modification, and addition of accessories must comply with published SnowEx recommendations and instructions. Available capacity decreases as the vehicle is loaded with cargo or other truck equipment, or snowplow accessories are installed.
- If there is uncertainty as to whether available capacity exists, the actual vehicle as configured must be weighed.

VEHICLE APPLICATION INFORMATION

BALLAST REQUIREMENTS

Ballast (additional weight) is an important part of qualifying vehicles for snowplow eligibility. Rear ballast must be used when necessary to remain in compliance with axle ratings and ratios as specified by the vehicle manufacturer.

If ballast is required, it is important that it be secured properly behind the rear axle. A ballast retainer kit is available from your SnowEx® outlet (PN 62849).

NOTE: The ballast retainer kit is for snowplow vehicles requiring ballast. See your SnowEx outlet for the correct amount of ballast required. Include the weight of the retainer as part of the ballast requirement. Sand bags are recommended for use as ballast.

NOTE: Ballast recommended and its weight calculations assume the entire width of the bed is filled as close to tailgate as possible.

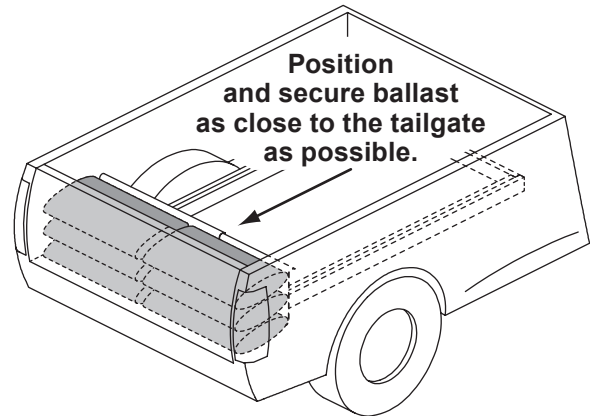

GETTING TO KNOW YOUR SNOWPLOW

Automatix® SYSTEM

The SnowEx® snowplow consists of all the components that are readily removable from the vehicle as a unit. This includes the blade, quadrant, headgear, A-frame, hydraulic unit, and the STORM SEEKER™ snowplow headlamps.

The snowplow is ready and easy to mount when you need to plow snow. After plowing, it is easily detached from the vehicle. When the snowplow is off the vehicle, the complete unit can be moved around on most hard surfaces.

The snowplow shall be installed according to instructions supplied. SnowEx outlets are trained to provide this service and other services for this snowplow.

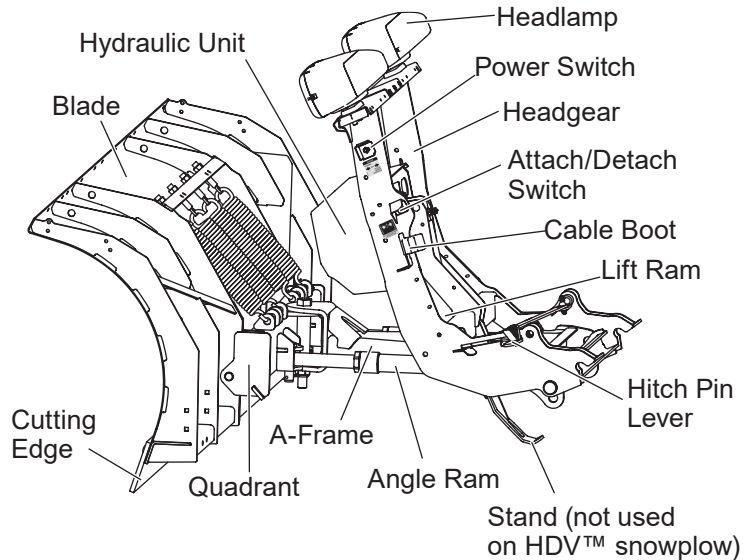

Actual configuration varies by model.

GETTING TO KNOW YOUR SNOWPLOW

BLADES

SnowEx® snowplows use high-strength steel components to maximize strength and reduce weight where necessary. All products feature vertical ribs for added strength and stability, and straight blades utilize a formed base channel.

SnowEx blades have replaceable high-carbon steel cutting edges bolted to the bottom. Cutting edges should be replaced when worn to the bottom edge of the blade. SPEEDWING™ wing cutting edges are adjustable for wear. (See the Maintenance section in this manual.)

A-FRAME/T-FRAME, QUADRANT, AND HEADGEAR

SPEEDWING™, POWER PLOW™, and Straight Blade Snowplows

The quadrant is attached to the back of the blade with heavy-duty trip springs and clevis pins with cotters. The trip springs allow the blade to trip forward and ride over obstacles such as low curbs, manhole covers, etc., without damaging the blade or the vehicle or injuring the driver. For trip spring adjustment instructions, see "Maintenance and Adjustment" in the Maintenance section of this manual.

The quadrant is attached to the triangular A-frame with a pivot bolt. The pivot bolt allows the quadrant and blade to swing right or left.

The hydraulic unit is easy to access and the cover can be removed without tools. It is conveniently located in front of the lift ram.

GETTING TO KNOW YOUR SNOWPLOW

The snowplow headlamps are also attached to the headgear.

HDV™ Snowplow

The blade wings are attached to the T-frame with a hinge pin, which allows the wings to extend and retract.

The hydraulic unit is mounted on the front of the headgear. The hoses remain connected to the hydraulic unit and the rams.

The snowplow headlamps are also attached to the headgear.

MOUNT KITS

Custom mounts have been designed for most vehicles. Due to differences among vehicle models, mounts are generally not interchangeable. The mount is fastened to the underside of the vehicle frame and provides the primary connecting point between the snowplow and the vehicle.

Two removable receiver brackets are attached to the mount using pins and hairpin cotters. The receiver brackets are easily removed to provide more road clearance during the non-plowing months of the year.

GETTING TO KNOW YOUR SNOWPLOW

STORM SEEKER™ SNOWPLOW HEADLAMPS

WARNING

Your vehicle must be equipped with snowplow headlamps and directional lights.

The snowplow headlamps include STORM SEEKER dual-beam halogen headlamps with combination park and turn signals. A pre-wired harness with a plug-in module requires no headlamp wire splicing. The headlamps conform to Federal Motor Vehicle Safety Standards (FMVSS).

When the electrical plugs are connected, the vehicle headlamps will automatically switch to the snowplow headlamps when they are turned ON. When the electrical plugs are disconnected, the headlamps will automatically switch to vehicle headlamps when they are turned ON.

Replacement parts are available through your local SnowEx® outlet.

GETTING TO KNOW YOUR SNOWPLOW

CAB CONTROLS

WARNING

To prevent accidental movement of the blade, always turn the control OFF whenever the snowplow is not in use. The power indicator light will turn OFF.

SnowEx® snowplows come equipped with one of two special controls: the POWER GRIP™ hand-held control or a joystick-style control.

The POWER PLOW™ snowplow control allows you to go from a WIDE PASS™ position, to a BUCKET BLADE™ (scoop) position, to a straight blade, all at the touch of a button or with a single lever movement.

The HDV™ snowplow control allows you to go from a V-plow to a BUCKET BLADE (scoop) position, to a straight blade, all at the touch of a button or with a single lever movement.

The vehicle ignition (key) switch controls a fused circuit that powers your cab control directly from the battery. The control is backlit, which will illuminate when the vehicle ignition is turned to ACC or ON.

The ON/OFF button on the cab control allows you to turn OFF the control and prevent blade movement even when the ignition switch is ON.

The control ON/OFF switch serves as an emergency stop, if required.

Turn the vehicle ignition switch to the "ON" or "ACCESSORY" position. The control backlight will illuminate. Press the ON/OFF button on the control. The power indicator light glows red, indicating the control is ON. The power indicator light glows red whenever the control and the vehicle ignition switch are both ON and the electrical connections to the snowplow are completed.

All controls are protected by a replaceable fuse located in the under hood snowplow electrical system. See "Fuse Replacement" in the Maintenance section of this manual.

GETTING TO KNOW YOUR SNOWPLOW

Straight Blade and SPEEDWING™ Snowplow Controls with FLEET FLEX System

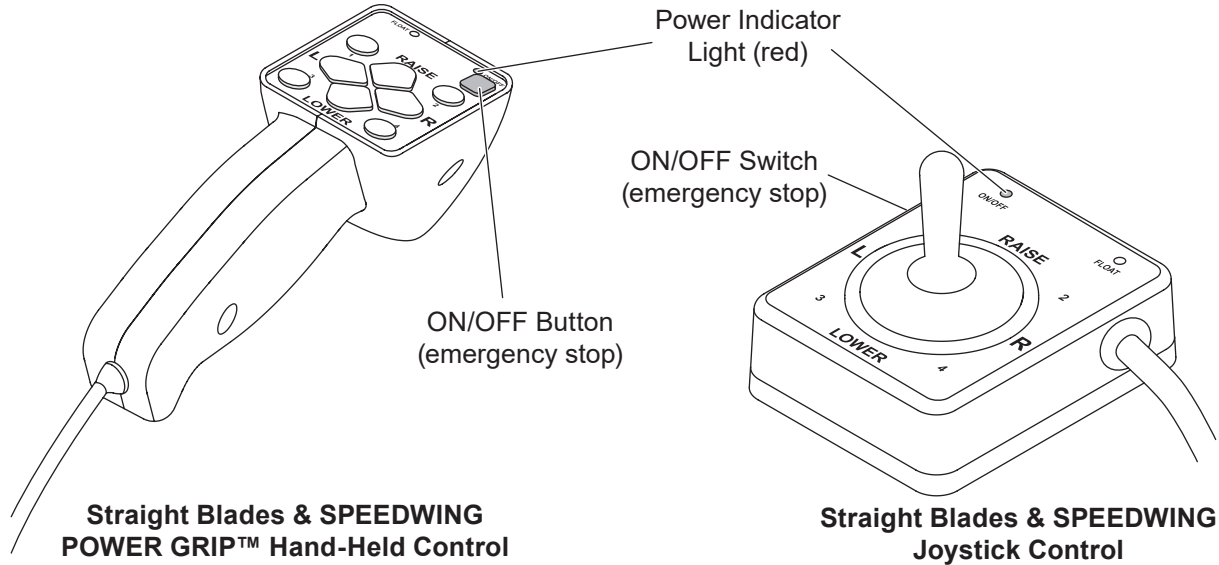

GETTING TO KNOW YOUR SNOWPLOW

POWER PLOW™ and HDV™ Snowplow Controls with FLEET FLEX System

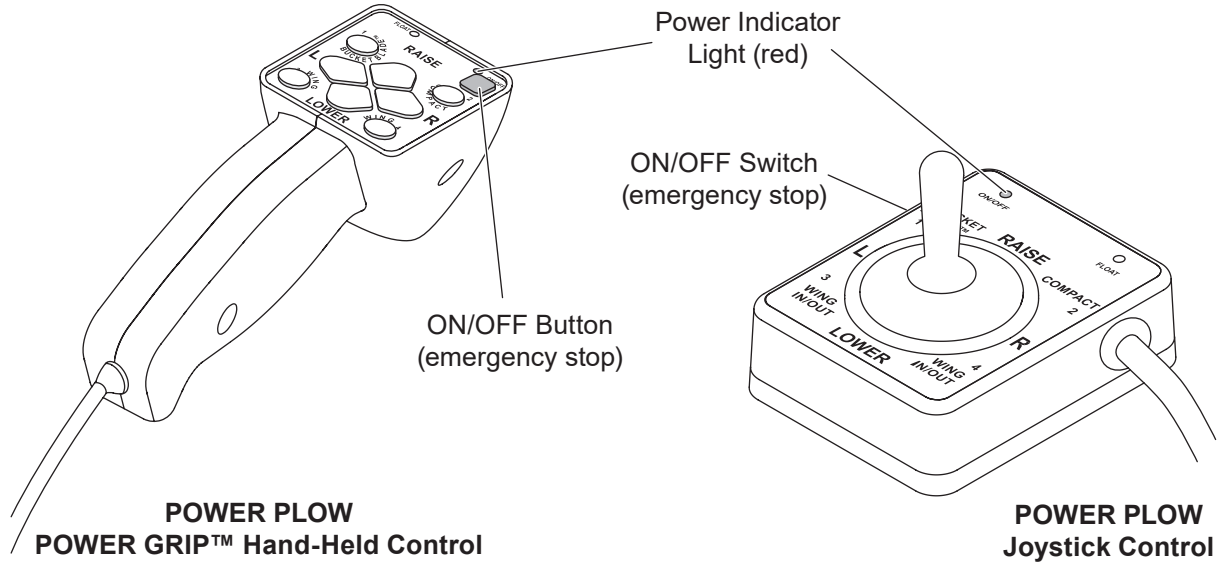

ACCESSORIES

SNOWPLOW ACCESSORIES

Extension Wings

Maximize your blade width and carrying capacity with wing extensions, reducing the number of passes to cut down job time. Available on HD straight blade and HDV™ snowplows.

Rubber Deflector – SnowEx®

Enhance snow containment and prevent snow from blowing onto the windshield with a SnowEx rubber deflector.

Thicker Steel Cutting Edges

Built for the long haul, SnowEx snowplows offer thicker steel cutting edges for enhanced wear resistance over time.

Poly Cutting Edges

Durable polyurethane cutting edge design withstands abuse while scraping up snow and ice from the surface.

Rubber Cutting Edges

Made to endure through heavy plow use, these durable edges provide added material for increased wear life.

Back Drag Edges

Deliver cleaner, consistent scraping and back dragging in tight areas.

Blade Shoe Kits

Help increase cutting edge life when plowing over abrasive surfaces such as gravel.

ACCESSORIES

OTHER ACCESSORIES

SnowEx® RAPID ACTION Hydraulic Fluid

Improve the performance of your hydraulic systems, especially in extremely cold weather, with SnowEx RAPID ACTION hydraulic fluid. Special anti-wear and anti-foaming additives keep your system running longer and smoother.

Emergency Parts Tool Kit

This tool bag contains necessary service parts to make on-the-spot repairs to your snowplow. The kit also includes a quart of SnowEx RAPID ACTION hydraulic fluid and an emergency chain kit.

The chain kit contains a chain with a removable link. It can be used to temporarily hold the blade in raised position for transport.



ATTACHING SNOWPLOW TO VEHICLE

ATTACHING SNOWPLOW

⚠ WARNING

Keep 8' (2.4 m) clear of the blade when it is being raised, lowered, or angled. Do not stand between vehicle and blade or directly in front of the blade. If the blade hits or drops on you, you could be seriously injured.

⚠ WARNING

Inspect snowplow components and bolts for wear or damage whenever attaching or detaching the snowplow. Worn or damaged components could allow the snowplow to drop unexpectedly.

NOTE: Use dielectric grease to prevent corrosion on all connections.

Attaching Steps:

1. Slowly drive vehicle forward to engage receiver pins into headgear slots.
2. Move power switch to center or "OFF" position.
3. Plug in electrical harnesses.

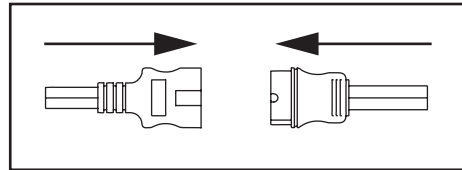

ATTACHING SNOWPLOW TO VEHICLE

4. Push and hold power switch and attach/detach operation switch RIGHT to rotate headgear up until hitch pins are aligned with the hitch pin holes on receivers. Release both switches.
5. Hold down lock lever and move hitch pin handle forward to fully engage hitch pins in receivers. Release lock lever to engage lock pin into hole in lock pin bracket.
6. Move power switch to LEFT or "PLOWING" position.

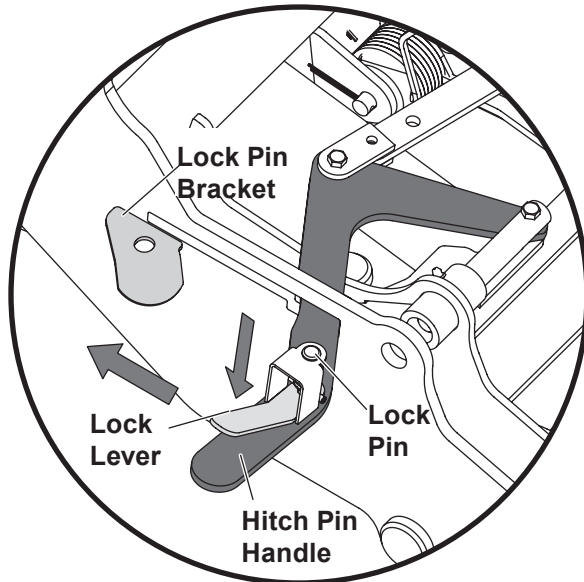

ATTACHING SNOWPLOW TO VEHICLE

POWER PLOW™, SPEEDWING™, and Straight Blades

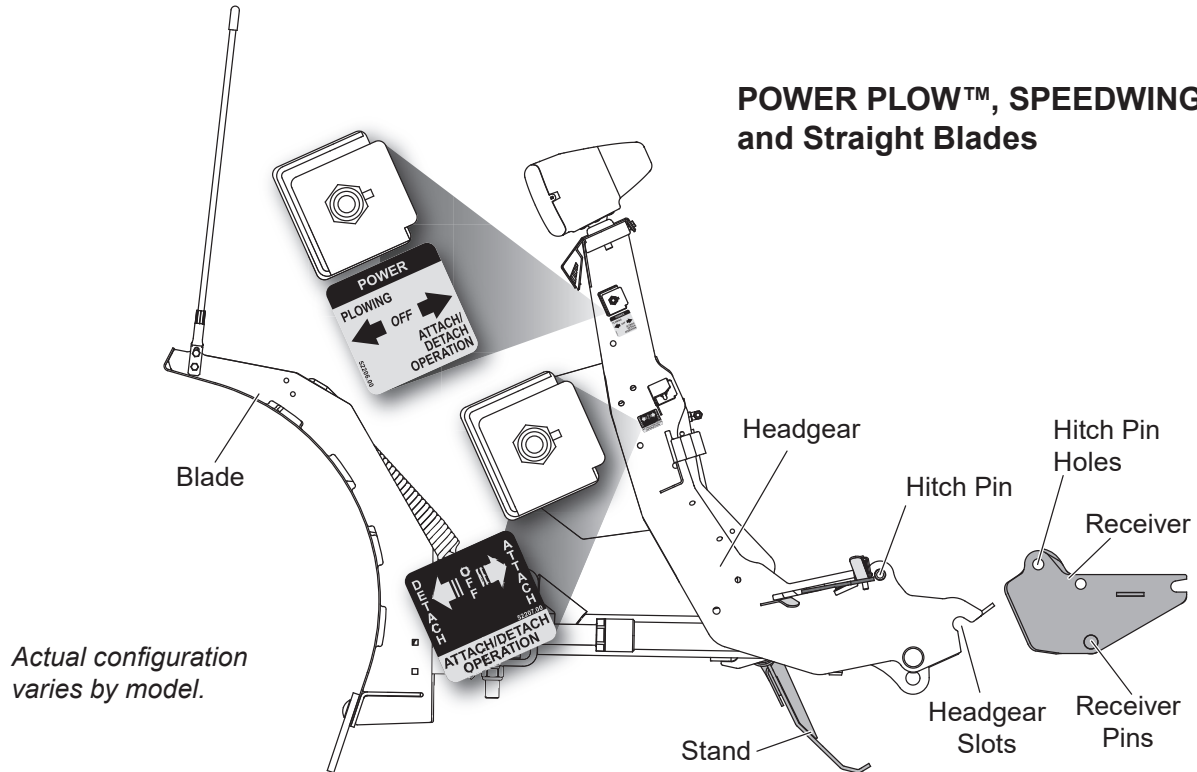

ATTACHING SNOWPLOW TO VEHICLE

HDV™ Blade

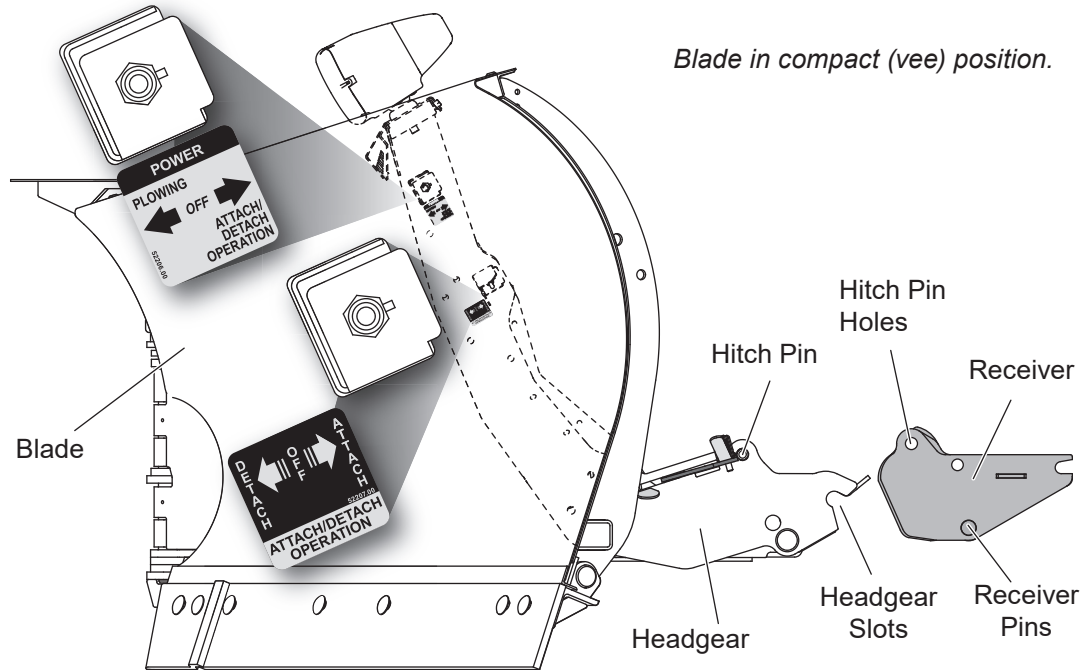

OPERATING YOUR SNOWPLOW

POWER GRIP™ STRAIGHT BLADE & SPEEDWING™ HAND-HELD CONTROL

⚠ WARNING

To prevent accidental movement of the blade, always push the ON/OFF button to switch the control OFF whenever the snowplow is not in use. The power indicator light will turn OFF.

1. Turn the vehicle ignition switch to the "ON" or "ACCESSORY" position. The control backlight will illuminate.
2. Press the ON/OFF button on the control. The power indicator light glows red, indicating the control is ON. The power indicator light glows red whenever the control and the vehicle ignition switch are both ON, the electrical connections to the snowplow are completed, and the plow power switch is in the "PLOWING" position.

The ON/OFF button operates as an emergency stop, if required.

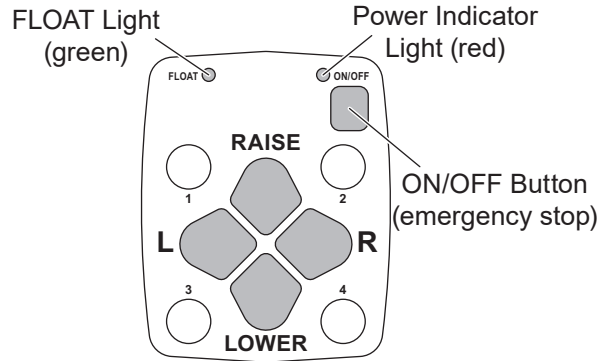

Function Time-Outs

All control functions, except LOWER/FLOAT, time out (stop) automatically after a period of time. This is to limit the amount of electrical energy required from the vehicle.

NOTE: If a control function times out before desired blade movement is complete, release the button and press it again.

OPERATING YOUR SNOWPLOW

Automatic Shutdown

The control will automatically turn OFF after being idle for 20 minutes. To reactivate the control after a shutdown, press the ON/OFF button.

Smooth Stop/Soft Stop

The control automatically allows the blade to coast to a stop when the button is released. This results in smoother operation, reduces the shock to the hydraulic system, and increases hose and valve life. See "FLEET FLEX Electrical System" in this section for more information.

Control Functions

RAISE, LOWER, FLOAT, Angle

The four diamond-shaped buttons in the center of the control face, when pressed, will result in the blade movements described in the table.

Function	Description of Operation
RAISE	Press this button to raise the blade and cancel FLOAT mode.
LOWER	Press this button to lower the blade. Release the button to stop the blade at desired height.
FLOAT[†]	Press the LOWER button and hold 3/4 second to activate this mode. The FLOAT light in the upper right corner of the control face will illuminate. The blade will lower to the ground surface and follow the contour of the surface as it dips or raises. Function does not time out; however, control will shut down after 20 minutes of nonuse. Press the RAISE button momentarily to cancel FLOAT. Angling left or right will not interrupt (pause) the FLOAT function.

[†] FLOAT mode activates immediately when one-touch FLOAT feature is enabled. See "One-Touch FLOAT" in this section for more information.

OPERATING YOUR SNOWPLOW

Function	Description of Operation
L (Angle Left)	Press this button to angle the blade left.
R (Angle Right)	Press this button to angle the blade right.

NOTE: If a control function times out before desired blade movement is complete, release the button and press it again.

SECURITY GUARD™ System (1, 2, 3, 4)

The four round buttons located to the left and right of the LOWER and RAISE buttons will also operate the SECURITY GUARD system (if equipped). See "SECURITY GUARD System" in this section for more information.

OPERATING YOUR SNOWPLOW

STRAIGHT BLADE & SPEEDWING™ JOYSTICK CONTROL

⚠ WARNING

To prevent accidental movement of the blade, always move the ON/OFF switch to OFF whenever the snowplow is not in use. The power indicator light will turn OFF.

1. Turn the vehicle ignition switch to the "ON" or "ACCESSORY" position. The control backlight will illuminate.
2. Move the ON/OFF switch on the side of the control to the "ON" position. The power indicator light glows red, indicating the control is ON. The indicator light glows red whenever the control and the vehicle ignition switch are both ON, the electrical connections to the snowplow are completed, and the plow power switch is in the "PLOWING" position.

The ON/OFF switch operates as an emergency stop, if required.

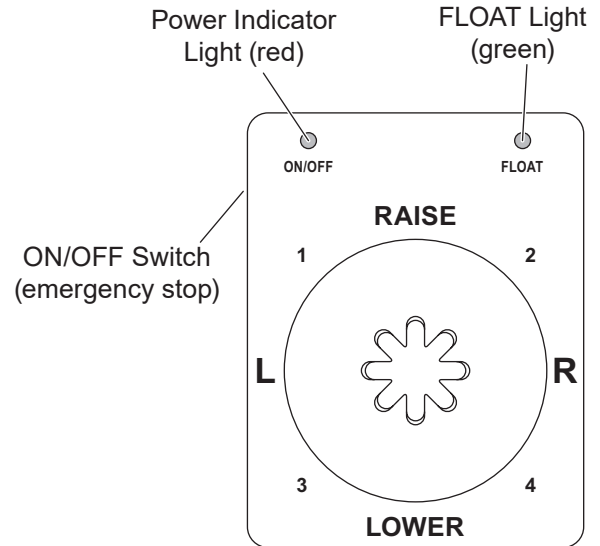

OPERATING YOUR SNOWPLOW

Function Time-Outs

All control functions, except LOWER/FLOAT, time out (stop) automatically after a period of time. This is to limit the amount of electrical energy required from the vehicle.

NOTE: If a control function times out before desired blade movement is complete, release the lever to the center position, then move it back into the desired function.

Automatic Shutdown

The control will automatically turn OFF after being idle for 20 minutes. To reactivate the control after a shutdown, move the ON/OFF switch to OFF, then back to ON.

Smooth Stop/Soft Stop

The control automatically allows the blade to coast to a stop when the lever returns to center position. This results in smoother operation, reduces the shock to the hydraulic system, and increases hose and valve life. See "FLEET FLEX Electrical System" in this section for more information.

Control Lever Movement

From the center position, the control lever can be moved in one of eight directions to control various movements of the snowplow blade. To change from one movement of the blade to another, the control lever must be moved back to the center position before selecting the desired function. Whenever the lever is released, it should spring back into the center position to stop any blade movement.

OPERATING YOUR SNOWPLOW

Control Functions

Raise, Lower, Float, Angle

Moving the control lever straight up and down or from side to side on the control body will result in the blade movements described in the following tables.

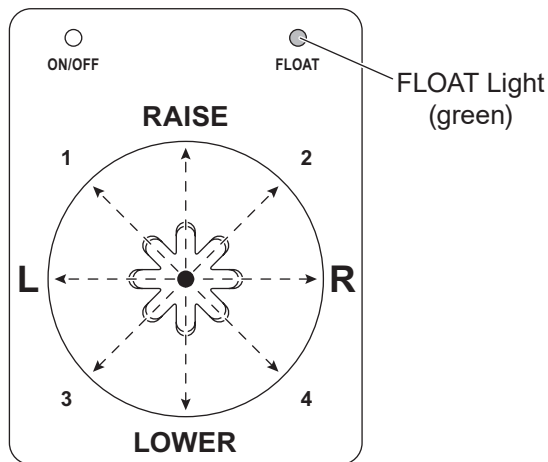

Function	Description of Operation
RAISE	Move the control lever toward the top of the control body to raise the blade and cancel the FLOAT mode.
LOWER	Move the control lever toward the bottom of the control body to lower the blade. Release the lever to stop the blade at the desired height.
FLOAT†	Move the control lever to the LOWER position and hold 3/4 second to activate this mode. The FLOAT light in the upper right corner of the control face will illuminate. The blade will lower to the ground surface and follow the contour of the surface as it dips or raises. Function does not time out; however, control will shut down after 20 minutes of nonuse. Move lever to the RAISE position momentarily to cancel FLOAT. Angling left or right will not interrupt (pause) the FLOAT function.

† FLOAT mode activates immediately when one-touch FLOAT feature is enabled. See "One-Touch FLOAT" in this section for more information.

OPERATING YOUR SNOWPLOW

Function	Description of Operation
L (Angle Left)	Move the control lever straight to the left to angle the blade left.
R (Angle Right)	Move the control lever straight to the right to angle the blade right.

NOTE: If a control function times out before desired blade movement is complete, release the lever to the center position, then move it back into the desired function.

SECURITY GUARD™ System (1, 2, 3, 4)

Moving the control lever from the center position toward any of the four digits on the face of the control body will also operate the SECURITY GUARD system (if equipped). See "SECURITY GUARD System" in this section for more information.

OPERATING YOUR SNOWPLOW

POWER GRIP™ POWER PLOW™ & HDV™ HAND-HELD CONTROL

⚠ WARNING

To prevent accidental movement of the blade, always push the ON/OFF button to switch the control OFF whenever the snowplow is not in use. The power indicator light will turn OFF.

1. Turn the vehicle ignition switch to the "ON" or "ACCESSORY" position. The control backlight will illuminate.
2. Press the ON/OFF button on the control. The power indicator light glows red, indicating the control is ON. The power indicator light glows red whenever the control and the vehicle ignition switch are both ON, the electrical connections to the snowplow are completed, and the plow power switch is in the "PLOWING" position.

The ON/OFF button operates as an emergency stop, if required.

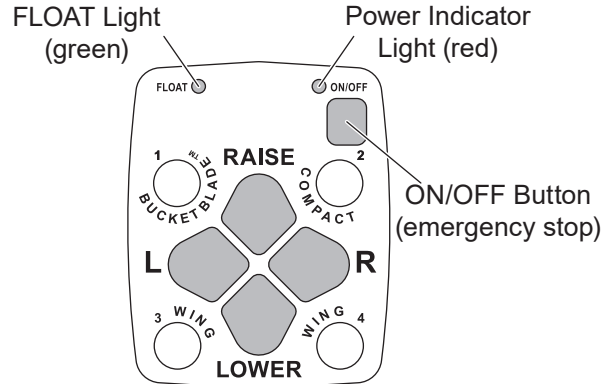

Function Time-Outs

To limit the amount of electrical energy required from the vehicle, all control functions, except LOWER/FLOAT, time out (stop) automatically after a period of time. The blade will coast to a stop. The time-outs are written into the programming and vary by snowplow model.

NOTE: If a control function times out before desired blade movement is complete, release the button and press it again.

OPERATING YOUR SNOWPLOW

Automatic Shutdown

The control will automatically turn OFF after being idle for 20 minutes. To reactivate the control after a shutdown, press the ON/OFF button.

Smooth Stop/Soft Stop

The control automatically allows the blade to coast to a stop when the button is released. This results in smoother operation, reduces the shock to the hydraulic system, and increases hose and valve life. See "FLEET FLEX Electrical System" in this section for more information.

Control Functions

RAISE, LOWER, FLOAT, Angle

The four diamond-shaped buttons in the center of the control face, when pressed, will result in the blade movements described in the table.

Function	Description of Operation
RAISE	Press this button to raise the blade and cancel the FLOAT mode.
LOWER	Press this button to lower the blade. Release the button to stop the blade at desired height.
FLOAT [†]	Press the LOWER button and hold 3/4 second to activate this mode. The FLOAT light in the upper right corner of the control face will illuminate. The blade will lower to the ground surface and follow the contour of the surface as it dips or raises. Function does not time out; however, the control will shut down after 20 minutes of nonuse. Press the RAISE button momentarily to cancel FLOAT. Angling left or right will not interrupt (pause) the FLOAT function.

[†] FLOAT mode activates immediately when one-touch FLOAT feature is enabled. See "One-Touch FLOAT" in this section for more information.

OPERATING YOUR SNOWPLOW

Function	Description of Operation
L (Angle Left)	With wings in a straight line, press the L button to move the blade to the angle left position. <i>HDV™ blade: The left wing retracts while the right wing extends.</i>
R (Angle Right)	With wings in a straight line, press the R button to move the blade to the angle right position. <i>HDV blade: The right wing retracts while the left wing extends.</i>

NOTE: If a control function times out before desired blade movement is complete, release the button and press it again.

BUCKET BLADE™/Compact Blade Positions

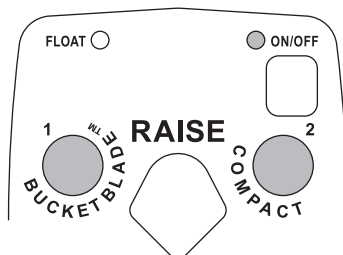

The two round buttons located to the left and right of the RAISE button move both wings at the same time into the blade positions described in the following table.

Function	Description of Operation
BUCKET BLADE	Press this button to extend both wings forward into the BUCKET BLADE position.
COMPACT	Press this button to draw both wings into the fully-retracted position.

OPERATING YOUR SNOWPLOW

Wing Positions

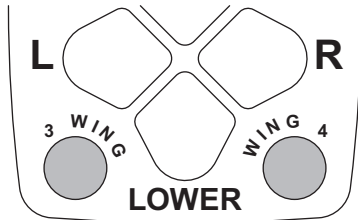

The two round buttons located to the left and right of the LOWER button move either wing independently of the other as described in the following table.

SECURITY GUARD™ System (1, 2, 3, 4)

The four round buttons located to the left and right of the LOWER and RAISE buttons will also operate the SECURITY GUARD system. See "SECURITY GUARD System" in this section for more information.

Function	Description of Operation
L WING	Press this button on the left side of the control to move the left wing. The first time the button is pressed after the control is turned ON or another function is used, the wing will extend. Repeated use of the same button, without using another function, results in movement in the opposite direction from the previous movement.
R WING	Press this button on the right side of the control to move the right wing. The first time the button is pressed after the control is turned ON or another function is used, the wing will extend. Repeated use of the same button, without using another function, results in movement in the opposite direction from the previous movement.

OPERATING YOUR SNOWPLOW

POWER PLOW™ & HDV™ JOYSTICK CONTROL

⚠ WARNING

To prevent accidental movement of the blade, always move the ON/OFF switch to OFF whenever the snowplow is not in use. The power indicator light will turn OFF.

1. Turn the vehicle ignition switch to the "ON" or "ACCESSORY" position. The control backlight will illuminate.
2. Move the ON/OFF switch on the side of the control to the "ON" position. The power indicator light glows red, indicating that the control is ON. The indicator light glows red whenever the control and the vehicle ignition switch are both ON, the electrical connections to the snowplow are completed, and the plow power switch is in the "PLOWING" position.

The ON/OFF switch operates as an emergency stop, if required.

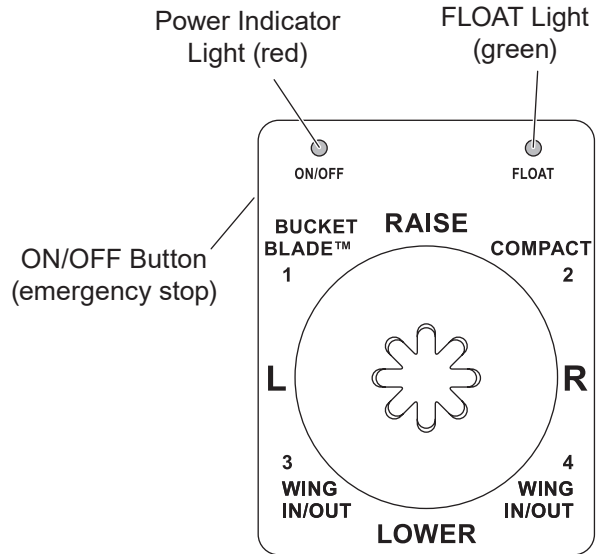

OPERATING YOUR SNOWPLOW

Function Time-Outs

All control functions, except LOWER/FLOAT, time out (stop) automatically after a period of time. This is to limit the amount of electrical energy required from the vehicle.

NOTE: If a control function times out before desired blade movement is complete, release the lever to the center position, then move it back into the desired function.

Automatic Shutdown

The control will automatically turn OFF after being idle for 20 minutes. To reactivate the control after a shutdown, move the ON/OFF switch to OFF, then back to ON.

Smooth Stop/Soft Stop

The control automatically allows the blade to coast to a stop when the lever returns to center position. This results in smoother operation, reduces the shock to the hydraulic system, and increases hose and valve life. See "FLEET FLEX Electrical System" in this section for more information.

Control Lever Movement

From the center position, the control lever can be moved in one of eight directions to control various movements of the snowplow blade. To change from one movement of the blade to another, the control lever must be moved back to the center position before selecting the desired function. Whenever the lever is released, it should spring back into the center position to stop any blade movement.

OPERATING YOUR SNOWPLOW

Control Functions

RAISE, LOWER, FLOAT, Angle

Moving the control lever straight up and down or from side to side on the control body will result in the blade movements described in the following tables.

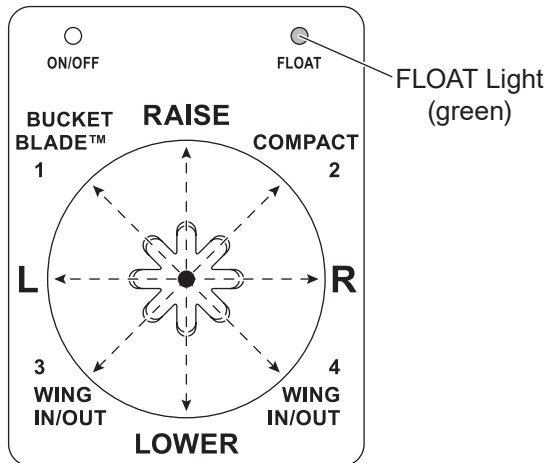

Function	Description of Operation
RAISE	Move the control lever toward the top of the control body to raise the blade and cancel the FLOAT mode.
LOWER	Move the control lever toward the bottom of the control body to lower the blade. Release the lever to stop the blade at the desired height.
FLOAT†	Move the control lever to the LOWER position and hold 3/4 second to activate this mode. The FLOAT light in the upper right corner of the control face will illuminate. The blade will lower to the ground surface and follow the contour of the surface as it dips or raises. Function does not time out; however, control will shut down after 20 minutes of nonuse. Move lever to the RAISE position momentarily to cancel FLOAT. Angling left or right will not interrupt (pause) the FLOAT function.

† FLOAT mode activates immediately when one-touch FLOAT feature is enabled. See "One-Touch FLOAT" in this section for more information.

OPERATING YOUR SNOWPLOW

Function	Description of Operation
L (Angle Left)	With wings in a straight line, move the control lever straight to the left to move the blade to the angle left position. <i>HDV™ blade: The left wing retracts while the right wing extends.</i>
R (Angle Right)	With wings in a straight line, move the control lever straight to the right to move the blade to the angle right position. <i>HDV blade: The right wing retracts while the left wing extends.</i>

BUCKET BLADE™/Compact Blade Positions

Moving the control lever from the center position toward the words "BUCKET BLADE" or "COMPACT" on the face of the control body will cause both wings to move at the same time into the following blade positions.

Function	Description of Operation
BUCKET BLADE	Move the control lever toward the words BUCKET BLADE on the control face to extend both wings forward into the BUCKET BLADE position.
COMPACT	Move the control lever toward the word COMPACT on the control face to fully retract both wings.

NOTE: If a control function times out before the desired blade movement is complete, release the lever to the center position, then move it back into the desired function.

OPERATING YOUR SNOWPLOW

Wing Positions

Moving the control lever from the center position toward the words WING IN/OUT, on either side of the face of the control body, will cause either wing to move independently of the other as described in the following table.

NOTE: If a control function times out before the desired blade movement is complete, release the lever to the center position, then move it back into the desired function.

SECURITY GUARD™ System (1, 2, 3, 4)

Moving the control lever from the center position toward any of the four numbers on the face of the control will also operate the SECURITY GUARD system. See "SECURITY GUARD System" in this section for more information.

Function	Description of Operation
L WING IN/OUT	Move the control lever toward the <i>left</i> side of LOWER on the control face to move the left wing. The first time the lever is moved into the slot after the control is turned ON or another function is used, the wing will extend. Repeated use of the lever in the same slot, without using another function, results in movement in the opposite direction from the previous movement.
R WING IN/OUT	Move the control lever toward the <i>right</i> side of LOWER on the control face to move the right wing. The first time the lever is moved into the slot after the control is turned ON or another function is used, the wing will extend. Repeated use of the lever in the same slot, without using another function, results in movement in the opposite direction from the previous movement.

FLEET FLEX ELECTRICAL SYSTEM

Your Automatixx® system snowplow comes standard with user-controlled programmable features. These include:

- SECURITY GUARD™ electrical anti-theft system
- Smooth stop/soft stop
- One-touch FLOAT

This section provides more information about each feature, as well as instructions on how to enable or disable them. These features are offered to give you the ability to secure your snowplow and customize your plowing experience.

SECURITY GUARD™ System**Activation & Establishing a 4-Digit Security Code**

NOTE: The snowplow must be attached to the vehicle, and all the electrical connections must be connected prior to activating the security code function.

The SECURITY GUARD feature was developed as an electrical anti-theft system. The system provides a deterrent from theft and/or non-permitted use by allowing you to electronically lock the snowplow's hydraulic functions.

All multiplex snowplow controls come equipped with the SECURITY GUARD system. To use this function, you must complete the activation process.

1. Turn the vehicle ignition switch to the "ON" or "ACCESSORY" position. The control backlight will illuminate. (It is not necessary to start the vehicle.)
2. Verify that the control power indicator is OFF. If the power indicator light is red, the control is ON. Move the ON/OFF switch to "OFF" or push the ON/OFF button to turn the control OFF.
3. To activate the SECURITY GUARD mode, move the control lever to the #1 position or press the #1 button four consecutive times, then move the lever to the #4 position or press the #4 button four times (sequence: 1, 1, 1, 1, 4, 4, 4, 4). The green FLOAT light will flash quickly and the red power indicator light will turn ON, indicating that the system is ready to accept your 4-digit security code.

Enter your 4-digit security code by moving the control lever to (or pressing the button for) any of the eight following positions: UP, DOWN, LEFT, RIGHT, 1, 2, 3, or 4.

Once you have entered your 4-digit security code, the FLOAT light will stop flashing and the power indicator light will turn OFF. This indicates that your 4-digit security code is entered and stored in the SECURITY GUARD™ system.

NOTE: If the control is turned ON prior to completing the programming procedure, your 4-digit security code will be cancelled.

4. Once a 4-digit security code is established and the plow/vehicle electrical connection is lost/disconnected, the SECURITY GUARD system will recognize any control that has been programmed with the same 4-digit security code. Any control not programmed with the correct 4-digit security code will require the user to enter the established security code before activating the snowplow (see the Manual Unlock procedure).

Manual Unlock

If the SECURITY GUARD system is activated and you are using a control with a different 4-digit code than the established security code, you will be required to manually enter the 4-digit security code before operating a locked snowplow.

1. Turn the vehicle ignition switch to the "ON" or "ACCESSORY" position. The control backlight will illuminate.
2. Move the ON/OFF switch to the "ON" position or push the ON/OFF button to switch the control ON.
3. The power indicator light will flash rapidly, indicating that the snowplow is locked.
4. Enter the 4-digit security code.

5. After the correct security code is entered, the power indicator light will change from rapid flashing to steady ON to indicate that the snowplow has been successfully unlocked.

NOTE: If the snowplow/vehicle electrical connection is lost or disconnected, the SECURITY GUARD™ system will reset, requiring any control that is not programmed with the established 4-digit security code to have its security code manually re-entered to activate the snowplow.

Clearing an Established 4-Digit Security Code

6. Turn the vehicle ignition switch to the "ON" or "ACCESSORY" position. The control backlight will illuminate.
7. If the snowplow is locked (the control power indicator light will be flashing rapidly), unlock the snowplow by following the Manual Unlock procedure described above.

8. Move the ON/OFF switch to the "OFF" position or push the ON/OFF button to switch the control OFF. Verify that the power indicator light is OFF.

9. With the control OFF, move the control lever to the #2 position or press the #2 button four consecutive times, then move the lever to the #3 position or press the #3 button four consecutive times. This sequence (2, 2, 2, 2, 3, 3, 3, 3) will clear the 4-digit security code from the SECURITY GUARD system. The FLOAT light will flash to indicate that the 4-digit security code was cleared.

NOTE: To enter a new 4-digit security code, see Activation & Establishing a 4-Digit Security Code.

Light Flash Indicators

POWER – Red	Function
OFF	Control is OFF
Solid ON	Control is ON and active
Slow Flash	No communication
Fast Flash	Snowplow is locked—enter 4-digit security code to unlock

FLOAT – Green	Function
Solid ON	FLOAT function is active
Fast Flash	Security code activation in progress

Additional Notes

- The SECURITY GUARD™ system requires any control (other than the one with the assigned 4-digit security code) to have the security code entered before the snowplow can be activated. Once the security code is established, the SECURITY GUARD system recognizes that a control with the same security code is connected and does not require a manual unlock to activate the snowplow. The system will recognize the control as "safe" and will automatically unlock.
- In the event that a snowplow is locked and cannot be manually unlocked or reset, contact your authorized dealer.
- **REMINDER:** Record your security code for future reference.

Smooth Stop/Soft Stop

Smooth stop, or soft stop, is a feature that allows the blade to coast to a stop when the button/lever is released. This results in smoother operation, reduces the shock to the hydraulic system, and increases hose and valve life.

While there are advantages to having this feature, there are also advantages to temporarily disabling it. For example, disabling smooth stop allows for more precise movements of the blade while operating close to buildings and other obstacles.

All controls come standard with this feature enabled. To enable/disable this feature, perform the following steps. Performing the sequence multiple times will toggle the feature between enabled and disabled.

Enable/Disable Procedure

1. Turn the vehicle ignition switch to the "ON" or "ACCESSORY" position. The control backlight will illuminate. (It is not necessary to start the vehicle.)
2. Verify that the control power indicator is OFF. If the power indicator light is red, the control is ON. Move the ON/OFF switch to "OFF" or push the ON/OFF button to turn the control OFF.
3. Move and hold the control lever to the "R" position or press and hold the R button while turning the control ON. The power indicator light will turn ON and the FLOAT light will flash, indicating the status of the feature.

Light Flash Indicators

Light	Description
POWER – Red	Solid ON = Control is ON
FLOAT – Green	1 Flash = Smooth stop enabled 2 Flashes = Smooth stop disabled

OPERATING YOUR SNOWPLOW

SPEEDWING™ BLADE POSITIONS

The SPEEDWING snowplow can be used in three basic plowing positions.

Scoop Blade

When blade is moved to straight-across orientation, both wings automatically angle into scoop position.

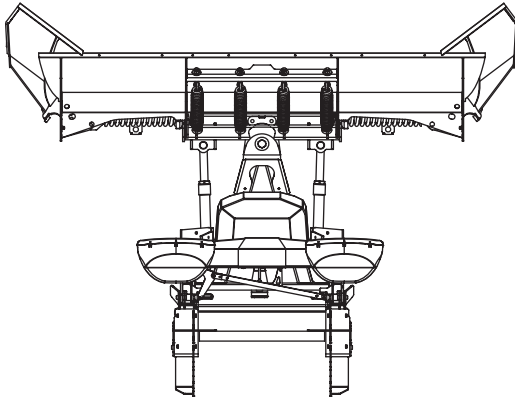

Windrow Blade

The wings automatically adjust in and out as the blade is angled left or right.

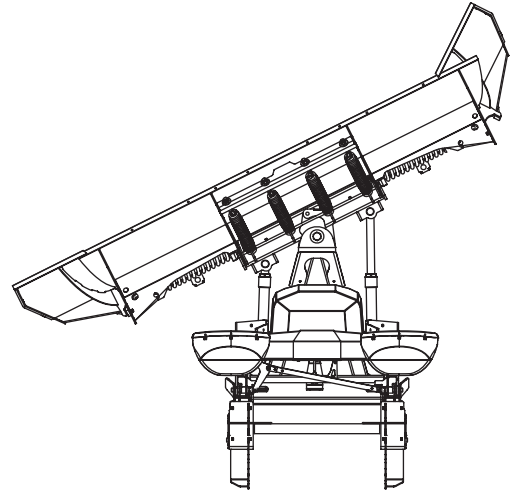

OPERATING YOUR SNOWPLOW

Straight Blade Option

The wings may be pinned in position to operate as a straight blade, using the hardware provided:

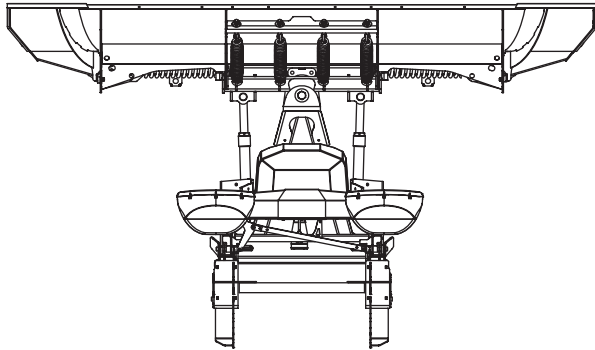

1. Fully angle the blade to one side. Lower the blade and turn the plow control and vehicle ignition OFF.

2. Standing behind the blade, install a 3/4" x 9" clevis pin down through the holes in the back of the blade assembly, as shown.
3. Secure the pin with a 1/8" hairpin cotter.
4. Repeat Steps 1–3 on the opposite side.

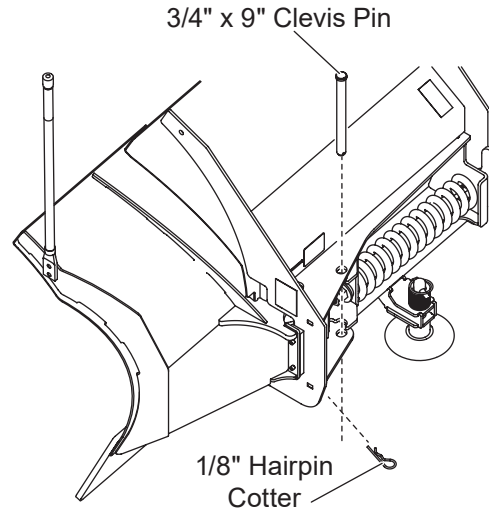

OPERATING YOUR SNOWPLOW

POWER PLOW™ BLADE POSITIONS

The POWER PLOW snowplow can be used in four basic plowing positions.

NOTE: Always transport the POWER PLOW snowplow with both wings fully retracted.

Compact Blade

Both wings retracted to form a straight blade.

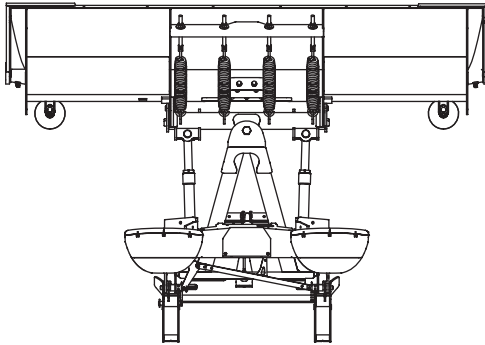

BUCKET BLADE™ (Scoop) Position

Extend both wings out and away from the vehicle to form a scoop to carry snow with minimum spilloff.

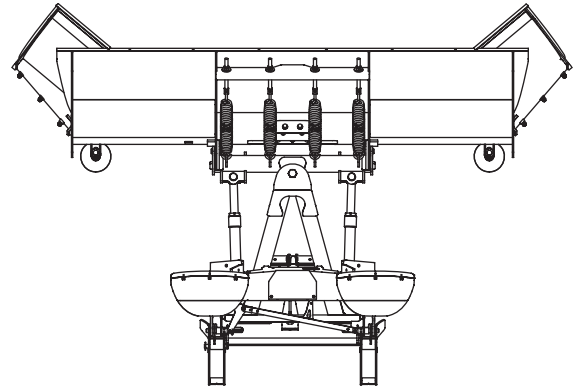

OPERATING YOUR SNOWPLOW

Windrow Blade

One wing moved OUT to extended position and the other wing moved OUT to scoop position for cleaning up windrows.

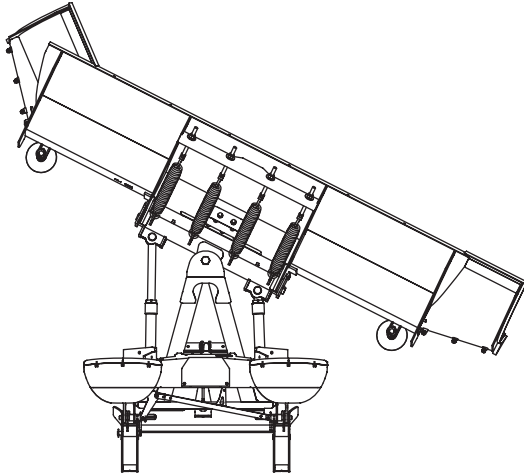

WIDE PASS™ Blade

Move both wings moved OUT to extended position to create an extra-wide straight blade for clearing large areas.

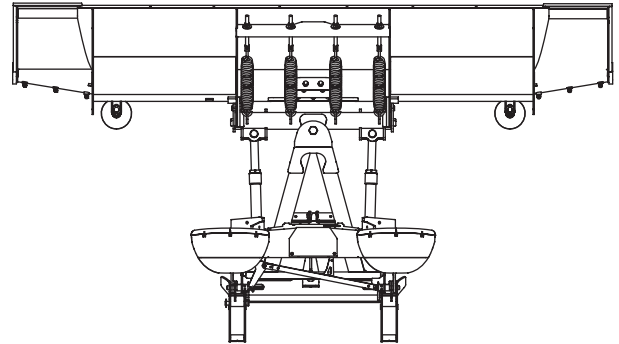

OPERATING YOUR SNOWPLOW

HDV™ BLADE POSITIONS

NOTE: For best road clearance during transport, place the blade halfway between the straight and compact (vee) positions. The **BUCKET BLADE™** (scoop) position is **NOT RECOMMENDED** during transport.

The HDV snowplow can be used in five basic plowing positions.

Straight Blade

Move both wings to form a straight blade for wide-path plowing or stacking snow.

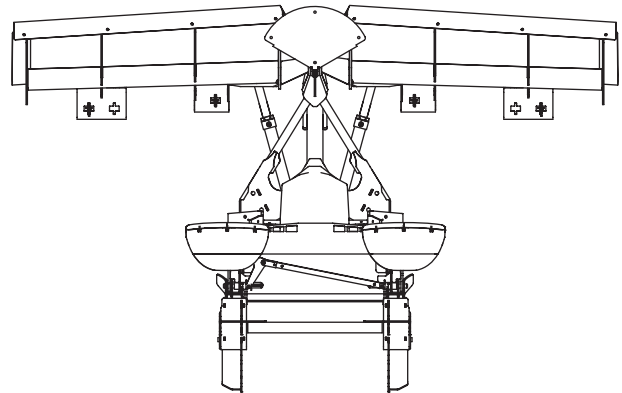

OPERATING YOUR SNOWPLOW

Angled Blade

Move one wing OUT and the other wing IN to form an angled blade in either direction for general plowing and widening.

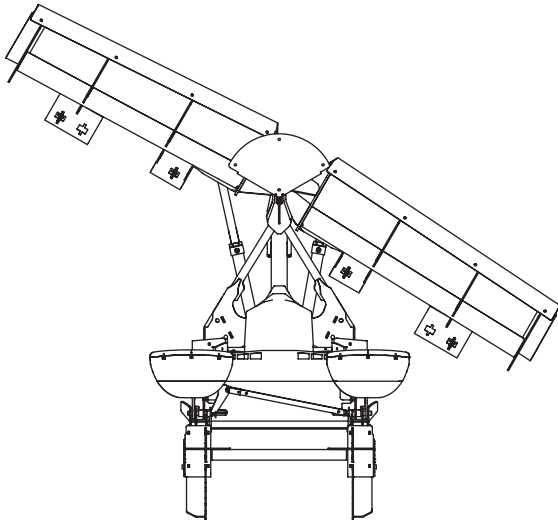

Compact (Vee) Blade

Move both wings IN toward the vehicle for initial break-through plowing and plowing paths or walkways.

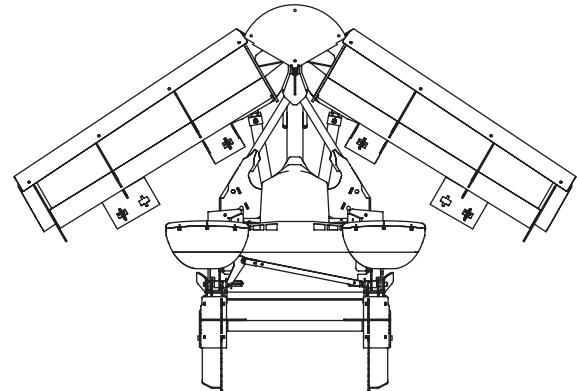

OPERATING YOUR SNOWPLOW

BUCKET BLADE™ (Scoop Position)

Extend both wings out and away from the vehicle to form a scoop to carry snow with minimum spilloff.

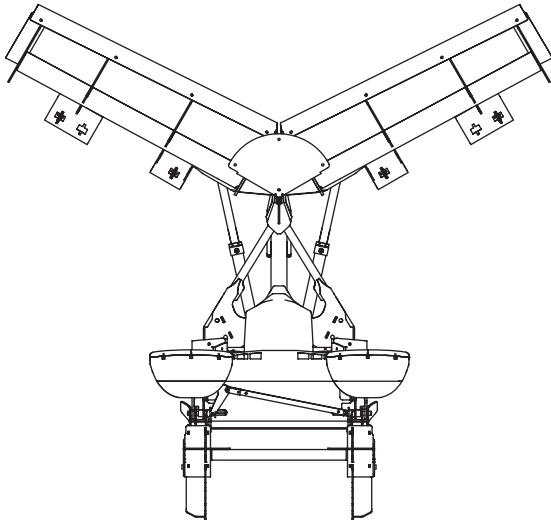

Dogleg Blade

Move one wing to straight blade position and the other OUT to scoop blade position for clean-up of windrows.

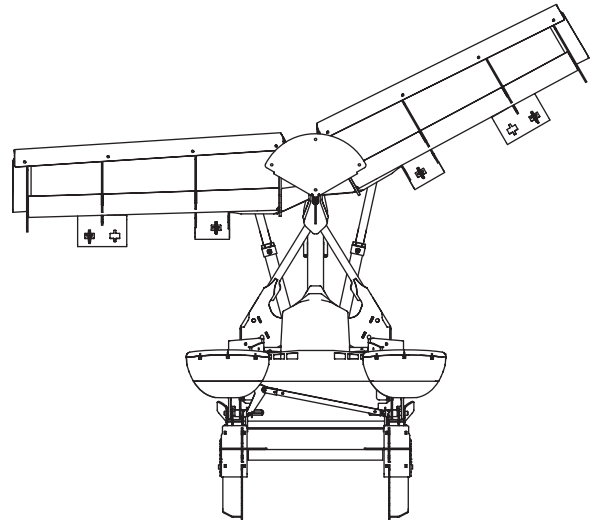

OPERATING YOUR SNOWPLOW

SNOWPLOW HEADLAMP CHECK

With all electrical plugs connected, check the operation of vehicle and snowplow headlamps.

Lights	Results
Parking Lamps	Both vehicle and snowplow lamps should be ON.
Right Turn Signal	Both vehicle and snowplow lamps should be ON.
Left Turn Signal	Both vehicle and snowplow lamps should be ON.

Connecting and disconnecting the electrical plugs should switch between the vehicle and snowplow headlamps as follows:

- Electrical plugs DISCONNECTED – Vehicle headlamps function normally.
- Electrical plugs CONNECTED – Vehicle headlamp functions transfer to the snowplow headlamps. On some Daytime Running Lamp (DRL) systems, both the vehicle and snowplow headlamps will function.

Aiming the Headlamps

- Aim the snowplow headlamps with the snowplow mounted and raised in the transport position. See "Aiming Headlamp Beams" in the Maintenance section for instructions.
- Aim the vehicle headlamps with the snowplow removed from the vehicle.

OPERATING YOUR SNOWPLOW

HYDRAULIC SYSTEM

Hydraulic Fluid

For hydraulic fluid type and filling instructions, see "Annual Fluid Change" under "Hydraulic System" in the Maintenance section of this manual.

Relief Valves

The hydraulic unit's valve manifold includes relief valves to prevent damage to the blade or vehicle if an obstacle is hit at either end of the blade. When force against the blade causes the pressure **in an extended ram** to exceed set limits, the relief valve opens, allowing fluid to escape, and the ram retracts.

The valves are preset at the factory and do not need any adjustments unless the valve manifold is serviced.

BLADE DROP SPEED ADJUSTMENT

WARNING

Keep 8' (2.4 m) clear of the blade when it is being raised, lowered, or angled. Do not stand between vehicle and blade or directly in front of the blade. If the blade hits or drops on you, you could be seriously injured.

The quill in the valve manifold adjusts the blade drop speed.

1. Lower the blade to the ground before making the adjustment.
2. Remove the hydraulic unit cover.

OPERATING YOUR SNOWPLOW

3. Turn the quill IN (clockwise) to decrease drop speed. Turn the quill OUT (counterclockwise) to increase drop speed.
4. Stand 8 feet clear of the blade when checking drop speed adjustment.
5. Replace the hydraulic unit cover.

POWER PLOW™, SPEEDWING™, and Straight Blades

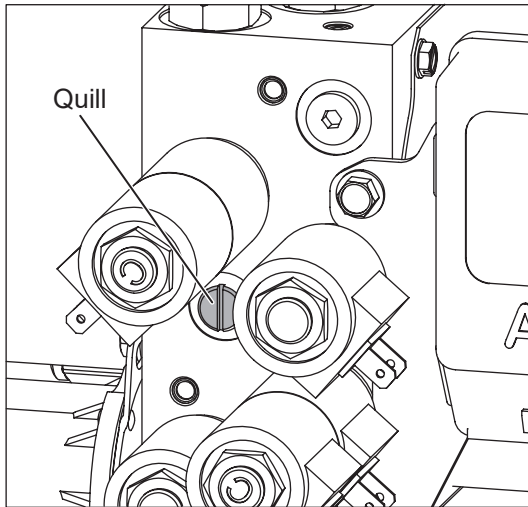

HDV™ Blades

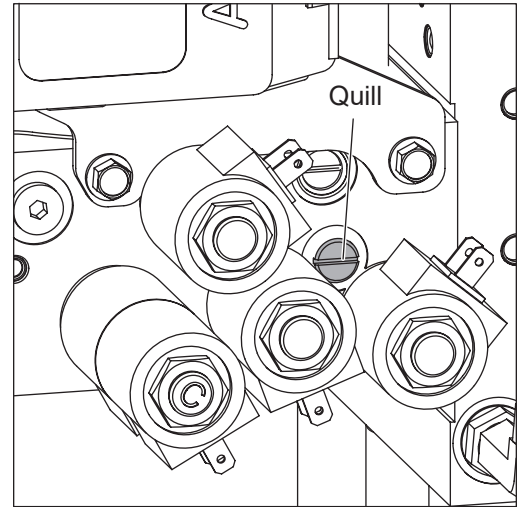

OPERATING YOUR SNOWPLOW

TRANSPORTING SNOWPLOW

WARNING

Position blade so that it does not block headlamp beam.

Do not change blade position while traveling. You could suddenly lower blade accidentally.

CAUTION

Transport speed should not exceed 45 mph (72 km/h). Further reduce speed under adverse travel conditions.

NOTE: For HDV™ blades, use care when driving or entering driveways with the snowplow in the retracted (vee) position. The outer ends of the cutting edges could contact the ground.

NOTE: Always transport the **POWER PLOW™** snowplow with both wings fully retracted.

1. Completely raise the blade.
2. Adjust the blade height for maximum snowplow headlamp illumination.
3. Adjust the blade to the straight position.
4. Turn the control OFF to lock the blade in place.

NOTE: Overheating is unlikely under normal driving conditions, but occasionally the snowplow may be positioned where it deflects air away from the radiator. If this occurs, stop the vehicle and raise, lower, or angle the snowplow slightly to correct overheating.

NOTE: Only the driver should be in the vehicle cab when the snowplow is attached.

OPERATING YOUR SNOWPLOW

DRIVING AND PLOWING ON SNOW AND ICE

WARNING

Drinking then driving or plowing is very dangerous. Your reflexes, perceptions, attentiveness, and judgment can be affected by even a small amount of alcohol. You can have a serious or even fatal collision if you drive after drinking. Please do not drink and then drive or plow.

Refer to your vehicle owner's manual instructions for driving in snow and ice conditions. Remember, when you drive on snow or ice, your tires will not get good traction. You cannot accelerate as quickly, turning is more difficult, and you will need longer braking distance.

Wet and hard-packed snow or ice offers the worst tire traction. It is very easy to lose control. You will have difficulty accelerating. If you do get moving, you may have poor steering and difficult braking, which can cause you to slide out of control.

Here are some tips for driving in these conditions:

- Drive defensively.
- Do not drink, then drive or plow snow.
- Plow or drive only when you have good visibility for operating a vehicle.
- If you cannot see well due to snow or icy conditions, you will need to slow down and keep more space between you and other vehicles.
- Slow down, especially on higher-speed roads. Your headlamps can light up only so much road ahead.
- If you are tired, pull off in a safe place and rest.
- Keep your windshield and all glass on your vehicle clean to see around you.
- Dress properly for the weather. Wear layers of clothing; as you get warm you can take off layers.

OPERATING YOUR SNOWPLOW

PLOWING SNOW

WARNING

Never plow snow with head out the vehicle window. Sudden stops or protruding objects could cause personal injury.

CAUTION

Wear a seat belt when plowing snow. Hidden obstructions could cause the vehicle to stop suddenly resulting in personal injury.

CAUTION

Flag any obstructions that are hard to locate under snow to prevent damage to product or property.

CAUTION

Never stack snow with the blade angled. This could damage the snowplow or the vehicle bumper.

CAUTION

Plowing speed should not exceed 10 mph (16 km/h).

NOTE: Only the driver should be in the vehicle cab when the snowplow is attached.

OPERATING YOUR SNOWPLOW

General Instructions

1. Before plowing, make sure that you know of any obstructions hidden beneath the snow, such as bumper stops in parking lots, curbs, sidewalk edges, shrubs, fences, or pipes sticking up from the ground. If unfamiliar with the area to be plowed, have someone familiar with the area point out obstacles.
2. If possible and you have good visibility, plow during the storm rather than letting snow accumulate.
3. Do not exceed 10 mph (16 km/h) when plowing snow.
4. When you are stacking snow, begin raising the blade as you come close to the stack. This will let the blade ride up the stack.

Hard-Packed Snow

1. Raise the anti-wear shoes so that the cutting edge comes into direct contact with the pavement.
2. Use the lowest gear to place maximum power behind the cutting edge.
3. An angled blade is more effective for removing hard-packed snow.

Deep Snow

1. For SPEEDWING™ and straight blades, shear off top layers by plowing with the blade raised 3 to 4 inches (8 to 10 cm) for the initial pass.
2. For HDV™ and POWER PLOW™ blades, move the blade to the compact position and make an initial pass.

OPERATING YOUR SNOWPLOW

3. Bite into the edges using only a partial blade width until the job is cut down to size for full-blade plowing.

Rule of thumb:

- 6" (15 cm) of snow – plow with entire blade width;
- 9" (23 cm) of snow – plow with 3/4 blade width;
- 12" (30 cm) of snow – plow with 1/2 of the blade.

With a POWER PLOW™ blade in BUCKET BLADE™ position, plow all depths with entire blade width.

Experience and feel are the best guides.

4. When plowing deep snow, be sure to keep the vehicle moving.
5. Ballast is suggested for maximum traction. Secure ballast behind the rear axle. Do not exceed the vehicle's GVWR and GAWR.
6. For increased traction, use tire chains where legal.

Clearing Driveways

1. Head into the driveway with the blade angled and plow the snow away from any buildings. Widen the driveway by rolling snow away from any buildings.
2. If a building is at the end of the driveway, plow to within a vehicle length of the building. Push as much snow as possible off the driveway.
3. With a raised blade, drive through the remaining snow to the building. Drop the blade and back drag the snow away from the building at least one vehicle length. Repeat if necessary.
4. Back the vehicle up to the building and plow forward, removing the remaining snow from the driveway.
5. Check municipal ordinances for proper disposal of snow.

OPERATING YOUR SNOWPLOW

Clearing Parking Lots

1. Clear areas in front of buildings first. With the blade raised, drive up to the building. Drop the blade and back drag the snow away from the building. When snow is clear of the buildings, turn the vehicle around and push snow away from the buildings toward the outer edges of the lot.
2. Plow a single path down the center in the lengthwise direction.
3. With the blade in the scoop, angle, or windrow position, plow successive strips lengthwise until the area is cleared and snow is stacked around the outer edges.
4. If snow is too deep to clear in the above manner, clear the main traffic lanes as much as possible.

PARKING WITH SNOWPLOW ATTACHED

WARNING

Lower the blade when the vehicle is parked. Keep 8' (2.4 m) clear of the blade. Temperature changes could change hydraulic pressure, causing the blade to drop unexpectedly or damaging hydraulic components. Failure to do this could result in serious personal injury.

Whenever you park your vehicle, completely lower the blade to the ground.

TOWING A DISABLED OR STUCK VEHICLE

CAUTION

Do not use any snowplow or mount components as an attachment point when retrieving, towing, or winching a disabled or stuck vehicle.

DETACHING SNOWPLOW FROM VEHICLE & STORAGE

DETACHING SNOWPLOW

WARNING

Keep 8' (2.4 m) clear of the blade when it is being raised, lowered, or angled. Do not stand between vehicle and blade or directly in front of the blade. If the blade hits or drops on you, you could be seriously injured.

WARNING

Inspect snowplow components and fasteners for wear or damage whenever attaching or detaching the snowplow. Worn or damaged components could allow the snowplow to drop unexpectedly.

NOTE: SPEEDWING™, POWER PLOW™, or straight blades must be in the straight position when attaching or detaching the snowplow.

NOTE: The HDV™ blade must be in the compact (vee) position when attaching or detaching the snowplow.

During the off-season, the control can be removed. Disconnect the connector in the cab and store the control in the glove box of the vehicle.

Detaching Steps

1. From inside the vehicle, lower snowplow onto ground with the blade straight (POWER PLOW, SPEEDWING, or straight blades) or in compact (vee) position (HDV blades). Turn plow control in vehicle OFF.
2. Push and hold power switch RIGHT and push and hold attach/detach operation switch RIGHT momentarily to rotate headgear up and release load on hitch pins.

DETACHING SNOWPLOW FROM VEHICLE & STORAGE

3. Hold down lock lever to disengage lock pin and move hitch pin handle rearward into notch in end of slot to fully disengage hitch pins from receivers.

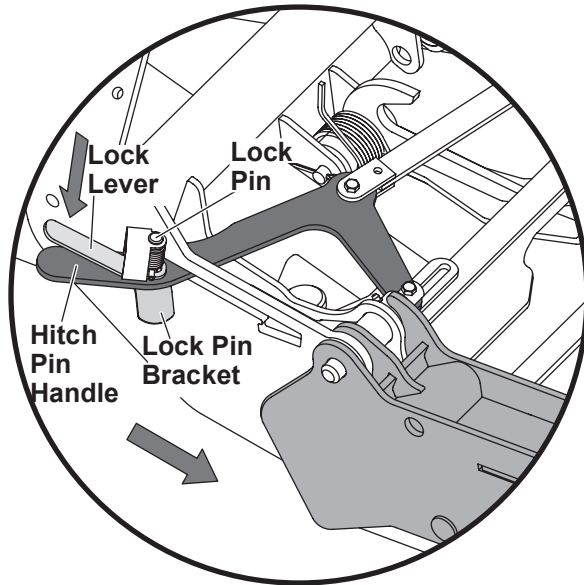

4. Push and hold power switch RIGHT and push and hold attach/detach operation switch LEFT to rotate headgear down until stand contacts ground (POWER PLOW™, SPEEDWING™, or straight blade snowplow) or headgear contacts T-frame (HDV™ snowplow) and hydraulic unit turns OFF.

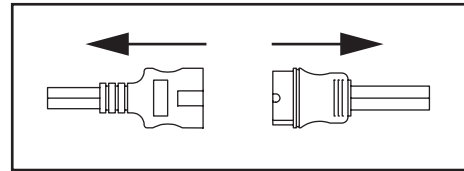

5. Unplug electrical harnesses.

NOTE: After each use of the snowplow, reapply dielectric grease to the electrical plugs to maintain the protective coating on the terminals.

NOTE: Reinstall plug covers on harnesses.

DETACHING SNOWPLOW FROM VEHICLE & STORAGE

POWER PLOW™, SPEEDWING™, and Straight Blades

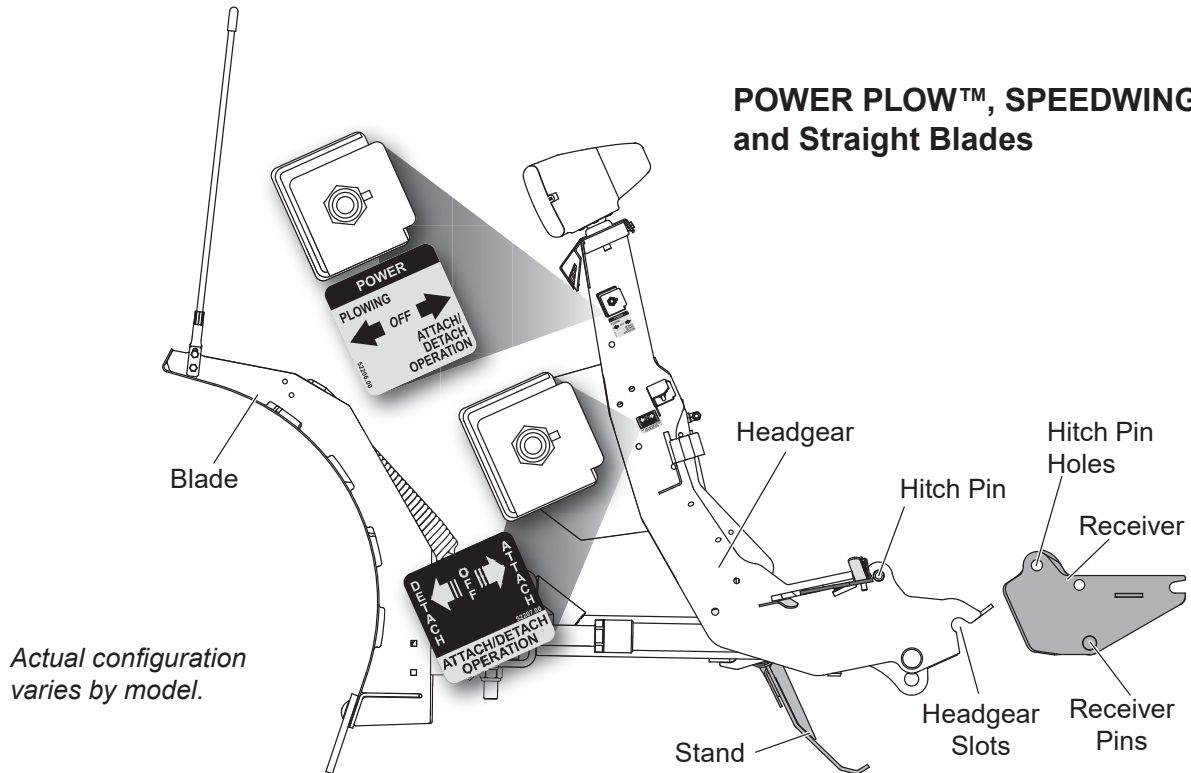

DETACHING SNOWPLOW FROM VEHICLE & STORAGE

HDV™ Blade

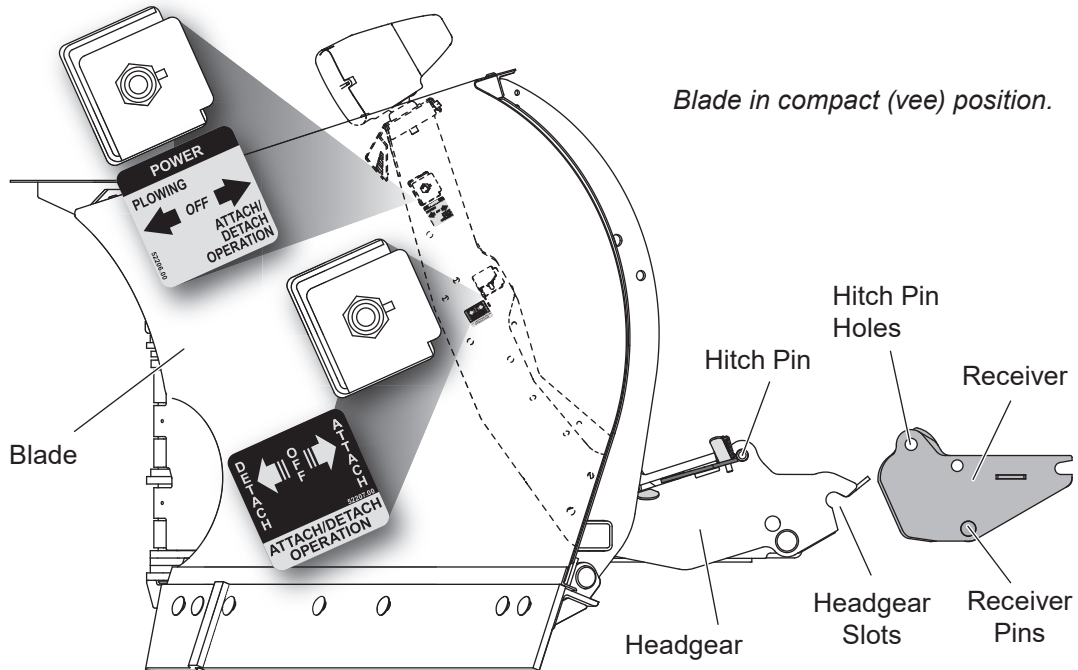

DETACHING SNOWPLOW FROM VEHICLE & STORAGE

CAUTION

On 2-plug electrical systems, plug covers shall be used whenever snowplow is disconnected. Vehicle battery cable is 12V unfused source.

STORAGE

Your snowplow is designed to be moved into a storage location using your vehicle and snowplow attachment system. For easier attaching of the snowplow, store it on a hard, level surface.

MAINTENANCE

MAINTENANCE VIDEOS

Video demonstrations of several snowplow maintenance tasks, including "Preseason Plow Maintenance" and "Annual Fluid Change," are available under the *Support* heading at www.snowexproducts.com.

PRESEASON CHECK

WARNING

Lower the blade when the vehicle is parked. Keep 8' (2.4 m) clear of the blade. Temperature changes could change hydraulic pressure, causing the blade to drop unexpectedly or damaging hydraulic components. Failure to do this could result in serious personal injury.

Before the snow season, check your equipment to make sure that it is in working condition. Here are some tips for getting your equipment ready:

- Clean and tighten all electrical connections and coat them with dielectric grease to prevent corrosion.
- Check the hydraulic system for leaks and cracked or damaged hoses.

MAINTENANCE

- Drain the hydraulic system and refill with recommended hydraulic fluid. For hydraulic fluid type and filling instructions, see "Annual Fluid Change" under "Hydraulic System" in this section of the manual.
- Replace worn or damaged parts.
- Check all mounting points and tighten fasteners on both snowplow and vehicle. Verify that all cotter pins are in place.
- Repaint the blade assembly and attachments, as necessary, to protect the metal.
- Install auxiliary and flashing lights for compliance and visibility in accordance with local regulations.
- Check headlamps, auxiliary lights, heater, and windshield wipers for proper operation.
- Inspect and test your battery. Recharge or replace as necessary.
- Ballast may be necessary, or beneficial, on some vehicles to provide maximum traction, braking, and handling.
- Any ballast material (such as sand and blocks) must be solidly secured to the vehicle, preventing the ballast from moving under harsh plowing conditions.

POSTSEASON MAINTENANCE

NOTE: Coat all electrical connections with dielectric grease.

- Clean and paint blade and attachments as needed.
- Apply general purpose petroleum grease to exposed chrome surfaces of the rams to prevent rust.
- Lubricate all pivot points and the hitch pin and stand pin grease zerks with general purpose petroleum grease.

MAINTENANCE

MAINTENANCE AND ADJUSTMENT

WARNING

Lower the blade when the vehicle is parked. Keep 8' (2.4 m) clear of the blade. Temperature changes could change hydraulic pressure, causing the blade to drop unexpectedly or damaging hydraulic components. Failure to do this could result in serious personal injury.

Your SnowEx® snowplow is designed for rugged, dependable service. However, like the vehicle on which it is mounted, it needs regular care and maintenance.

Check the following before and frequently during the plowing season:

- Make sure that all fasteners, mounting bolts, and hydraulic connections are tight.

- Make sure that all electrical connections, including grounds, are clean, tight, free of rust or corrosion, and coated with dielectric grease.
- Check all plugs and seals for hydraulic fluid leaks. Repair as necessary.
- Lubricate all moving parts. Not doing so will make operation of the mount difficult and possibly damage components.
For HDV™ V-plows, also see "Greasing HDV Pivot Pin Hinge" later in this section.
- **SPEEDWING™ Wing Cutting Edges:** To equalize wear, follow the procedures described in the Cutting Edge Wear and Leveling Adjustment section.

MAINTENANCE

- **Trip Spring Adjustment (Straight Blade, SPEEDWING™, and POWER PLOW™ snowplows):** To adjust trip spring tension, adjust the eyebolts located at the top of the blade. Loosen the locknut (nut closest to the spring) and tighten the adjusting nut (nut farthest from the spring) until the coils begin to separate. When tension is properly adjusted, a sheet of paper should pass between the second and third coils. When the proper tension is reached, tighten the locknut.
- **Blade Finish:** If the powder-coat finish is nicked or scratched, repair the surface and paint with SnowEx® gray or gloss black paint (available in aerosol or quart can).

GREASING HDV™ PIVOT PIN HINGE

Using a rubber-tipped seal-off coupler, apply a good quality multipurpose grease at the five grease points along the center pivot pin hinge.

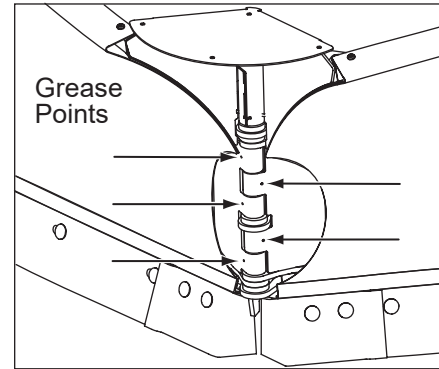

Grease the hinge at the beginning of the snowplow season. Reapply as needed during the season and before putting the snowplow in storage.

MAINTENANCE

AIMING HEADLAMP BEAMS

Tighten headlamp fasteners to 45 ft-lb once correct visual aim is achieved.

1. Place vehicle on a level surface 25 feet (7.62 m) in front of a matte-white screen, such as a garage door. The screen should be perpendicular both to the ground and to the vehicle centerline.
2. The vehicle should be equipped for normal operation. The snowplow blade should be in place and in raised position.

Following are steps listed by the Society of Automotive Engineers (SAE) pertinent to headlamp aiming in specification #SAE J599d.

3. Prepare vehicle for headlamp aim or inspection. Before checking beam aim, the inspector will:
 - a. Remove ice or mud from under fenders.
 - b. Set tire inflation pressures to the values specified on vehicle information label.
 - c. Check springs for sag or broken leaves.
 - d. See that there is no load in the vehicle other than the driver and ballast as specified in the Power Match selection system.
 - e. Check functioning of any automatic vehicle leveling systems and specific manufacturer's instructions pertaining to vehicle preparation for headlamp aiming.
 - f. Stabilize suspension by rocking vehicle sideways.
 - g. Clean headlamp lenses.
 - h. Check for bulb burnout and proper beam switching.

MAINTENANCE

4. Mark (or tape) the vertical centerline of the snowplow headlamps and the vertical centerline of the vehicle on the screen. Mark the horizontal centerline of the snowplow headlamps on the screen (distance from ground to snowplow headlamp centers).
5. Align the top edge of the high-intensity zone of the snowplow lower beam below the horizontal centerline and the left edge of the high-intensity zone along the vertical centerline for each snowplow headlamp. (Refer to the diagram below.)

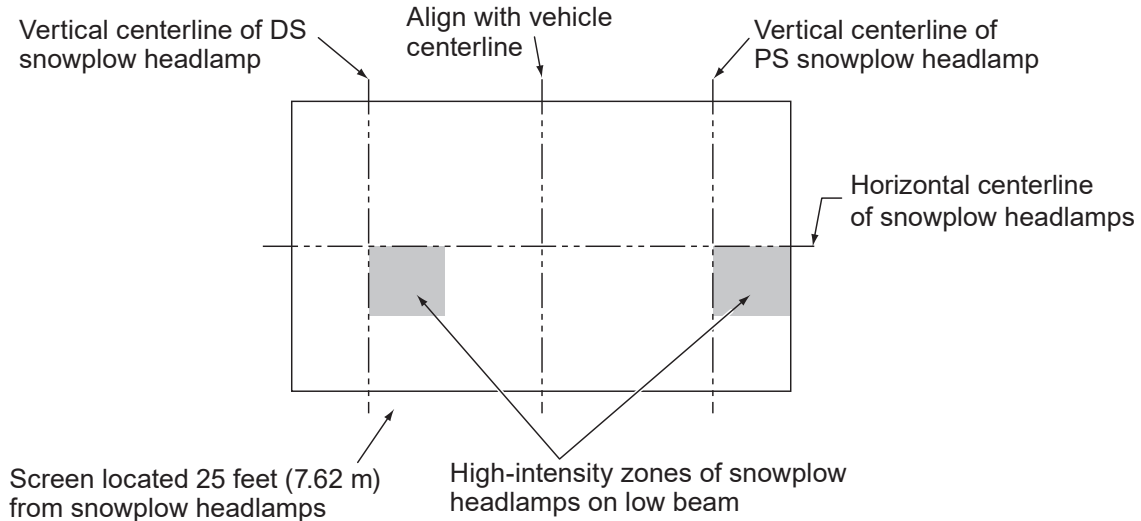

MAINTENANCE

HYDRAULIC SYSTEM

Fluid Level

⚠ CAUTION

Do not mix different kinds of hydraulic fluid. Some fluids are not compatible and may cause performance problems and product damage.

NOTE: On POWER PLOW™ and HDV™ blades, add fluid only when wings are retracted.

NOTE: Remove fill plug slowly to relieve any pressure in reservoir.

1. With the Automatixx® system attached to the vehicle, lower the blade to the ground. Turn the control OFF.

2. Remove the hydraulic cover.
3. Slowly remove the fill plug to check or add fluid.

SPEEDWING™, POWER PLOW™, and Straight Blades: Fluid level should be 2" to 3" (5 to 8 cm) below the top of the fill pipe.

HDV™ Blades: Fluid should be 1" to 1-1/2" (2.5 to 3.8 cm) below the top of the fill pipe.

Do not overfill. Replace the fill plug.

4. Replace the hydraulic unit cover.

For fluid recommendations see "Annual Fluid Change" in this section.

MAINTENANCE

Annual Fluid Change

WARNING

Keep 8' (2.4 m) clear of the blade when it is being raised, lowered, or angled. Do not stand between vehicle and blade or directly in front of the blade. If the blade hits or drops on you, you could be seriously injured.

CAUTION

Change the fluid at the beginning of each plowing season. Failure to do this could result in condensation buildup during the non-plowing season.

CAUTION

Do not mix different kinds of hydraulic fluid. Some fluids are not compatible and may cause performance problems and product damage.

1. Perform this operation with the snowplow attached to the truck on a hard, level surface. Disable the one-touch FLOAT feature, if enabled. (See "One-Touch FLOAT" in the Operating Your Snowplow section of this manual.)
2. Lower the blade to the ground. For SPEEDWING™ blades, move the blade to the scoop position so that both wings are forward. For POWER PLOW™ and HDV™ blades, fully retract the wings.
3. Remove the hydraulic unit cover.

NOTE: Loosen the fill plug slowly to relieve any pressure in the reservoir.

4. **SPEEDWING, POWER PLOW, or Straight Blades:** Remove the drain plug located in the bottom of the hydraulic reservoir.

HDV Blades: Remove the drain cap on the side of the valve manifold. (See illustration

MAINTENANCE

under "Hydraulic System" in the Getting to Know Your Snowplow section of this manual.

Completely drain the reservoir and replace the drain plug/cap.

5. Fill the reservoir with SnowEx® RAPID ACTION hydraulic fluid rated to –40°F (–40°C) or other fluid conforming to Military Specification MIL-H-5606 A, such as Mobil Aero HFA or Shell AeroShell® Fluid 4.

SPEEDWING™, POWER PLOW™, or Straight Blades: Fill reservoir to within 2" to 3" (5 to 8 cm) of the top of the fill pipe.

HDV™ Blades: Fill reservoir so that fluid is 1" to 1-1/2" (2.5 to 3.8 cm) below the top of the fill pipe.

Replace the fill plug.

6. Remove air by turning the control ON and fully angling the blade to the left and right several times. Turn the control OFF.
7. Add fluid to fill the reservoir to the proper level as specified in Step 5. Replace the fill plug.

NOTE: Loosen fill plug slowly to relieve any pressure in the reservoir.

8. Turn the control ON and raise and lower the snowplow several times. Turn the control OFF.
9. Add fluid to fill the reservoir to the proper level as specified in Step 5. Replace the fill plug.

WARNING

To prevent accidental movement of the blade, always turn the control OFF whenever the snowplow is not in use. The power indicator light will turn OFF.

MAINTENANCE

Hose or Fitting Replacement

WARNING

Lower blade when vehicle is parked. Keep 8' (2.4 m) clear of the blade. Temperature changes could change hydraulic pressure, causing the blade to drop unexpectedly or damaging hydraulic components. Failure to do this could result in serious personal injury.

DO NOT use thread sealant/tape on hoses or fittings. This could damage the product. Follow the recommended replacement procedures for fittings and hoses.

1. **POWER PLOW™ Blades:** Fully retract both wings.
SPEEDWING™ Blades: Move the blade to scoop position so that both wings are forward.
HDV™ Blades: Move the wings to the BUCKET BLADE™ (scoop) position. Ensure

that the rear of the plow is adequately supported.

2. Lower the snowplow completely and turn the control OFF.
3. Carefully note hose routings and position of any protective hose wraps for proper reassembly.

NOTE: Loosen fill plug slowly to relieve any pressure in the reservoir.

4. Loosen hoses or fittings slowly to relieve any residual pressure.
HDV Blades: When servicing the base end angle ram hoses or fittings, first remove the base end angle ram 1" (2.5 cm) pin.
5. To remove a hose, loosen and unscrew the hose flare nut from the fitting.
6. To remove a fitting, loosen the jam nut and unscrew the fitting from the port.

MAINTENANCE

Installing Hydraulic Fittings and Hoses

NOTE: Overtorquing JIC hose fitting ends will result in a fractured fitting.

DO NOT use any type of sealant or tape on fittings or hoses. This could damage the product. Always use two wrenches to ensure proper tightening of fittings and hoses.

Installing SAE O-Ring Fittings in Valve Block and Rams

1. Turn the fitting jam nut as far back as possible.
2. Lubricate the O-ring with clean hydraulic fluid.
3. Screw the fitting into the port by hand until the washer contacts the port face and shoulder of the jam nut threads.
4. Unscrew the fitting to the proper position, no more than one full turn.

5. Using two wrenches, hold the fitting body in position and tighten the jam nut until the washer again contacts the port face, then tighten an additional 1/8- to 1/4-turn to lock the fitting in place. Final torque on the jam nut should be approximately 20 ft-lb.

Installing Hydraulic Hoses

1. Screw the flare nut onto the fitting flare and hand tighten.
2. Align the hose so that there are no twists or sharp bends and so that it will not be pinched or pulled by moving parts.
3. Using a pair of adjustable pliers, hold the hose in position and use a wrench to tighten the flare nut 1/8–1/4 turn beyond hand tight. Final torque on the flare nut should be approximately 20 ft-lb.
4. Reinstall any protective hose wraps in their original positions.

MAINTENANCE

FUSE REPLACEMENT

The vehicle electrical system contains several automotive-style fuses. The snowplow park/turn and control power is covered by fuses in the under-hood snowplow wiring. The control fuse is "hot" when the vehicle ignition switch is ON and snowplow electrical connections are completed.

The hydraulic unit harness system contains three automotive-style mini fuses. The 4-solenoid harness (to port B on the hydraulic unit module) and 9-solenoid (HDV™) harness (to port C) each contain two 5A mini fuses.

The 2-solenoid (straight blades) or 6-solenoid (POWER PLOW™) harness (to port C) contains a single 5A mini fuse.

If a problem should occur and fuse replacement is necessary, the replacement fuse must be of the same type and amperage rating as the original. Installing a fuse with a higher rating can damage the system and could start a fire.

MAINTENANCE

SNOWPLOW VEHICLE BATTERY BEST PRACTICES

- Keep all battery connections tight and clean. Poor connections cause higher power consumption.
- Before the snow season, confirm that the battery is fully charged: 12.7V to 12.8V with the engine OFF. Beginning the plowing season with a weak battery results in deep-cycle depletion of the battery charge.
- If the battery charge level is low or questionable, hook up a battery charger when the vehicle is not in use. If the battery cannot achieve or maintain a full charge, replace it. (On dual-battery vehicles, always replace both batteries even if only one of them is bad.)
- Avoid leaving the snowplow vehicle parked (unused) for 3 weeks or longer.
- Parking a vehicle with the battery in a discharged state can result in permanent battery damage.
- Avoid operating the snowplow without the vehicle engine running.

MAINTENANCE

VEHICLE

The snowplow operating vehicle shall be maintained according to manufacturer's recommendations. Tire pressure shall be maintained according to manufacturer's recommendation.

RECYCLE

When your snowplow has performed its useful life, the majority of its components can be recycled as steel or aluminum. Hydraulic fluid shall be disposed of according to local regulations. The balance of the parts made of plastic shall be disposed of in a customary manner.

BLADE FINISH

If the powder-coat finish is nicked or scratched, repair the blade surface with SnowEx® gray paint in 12 oz (739 mL) aerosol or quart cans from your SnowEx outlet. Clean and repaint parts as necessary.

EMERGENCY PARTS/TOOLS

We suggest that you keep a SnowEx Emergency Parts Kit in your vehicle. This kit contains SnowEx hydraulic fluid, dielectric grease, common hoses, pins, clips, fasteners, and a motor relay.

Also keep the following items in your vehicle for emergency use:

- 10" (25 cm) adjustable wrench
- Pliers
- Medium screwdriver
- Miscellaneous fasteners

Always use SnowEx designed and tested replacement parts.

MAINTENANCE

TROUBLESHOOTING

If you have followed all of the guidelines in the Maintenance section of this manual and cannot resolve issues with the operation of your SnowEx® snowplow, contact one of our authorized outlets for repair information or visit us online at www.snowexproducts.com. Our website has a complete listing of authorized outlets in your area as well as a complete library of Parts Lists, Mechanic's Guides, and service information to assist the qualified mechanic with repair.

TrynEx International does not recommend repairs by other than our factory-trained outlets. Failure to use an authorized outlet could affect the warranty coverage on your snowplow.



SNOWPLOW SPECIFICATIONS & ACCESSORIES

SNOWPLOW WEIGHTS

Snowplow Weights			
Size	Blade Assembly	Wt (lb)	Wt (kg)
6'8"	6800LT	303	137
7'2"	7200LT	310	141
7'6"	7600RD	406	184
8'	8000RD	415	188
7'6"	7600HD	730	331
8'	8000HD	746.5	339
8'6"	8600HD	763.5	346
9'	9000HD	781.5	354
8'6"	8600SW SPEEDWING™	891.5	404
8'-10'	8100PP POWER PLOW™	970	440
8'6"-11'	8611PP POWER PLOW	1036	470
8'6"	8'6" HDV™	950	431
9'6"	9'6" HDV	1030	467

SNOWPLOW SPECIFICATIONS & ACCESSORIES

Snowplow	SPEEDWING™	HDV™ V-Plow	POWER PLOW™ 8100	POWER PLOW™ 8611
Blade Widths	103" (2.62 m) scoop; 100" (2.54 m) windrow	8'6" (2.59 m) 9'6" (2.9 m)	8' (2.44 m) retracted; 10' (3.05 m) expanded width; 9' (2.74 m) BUCKET BLADE™	8'6" (2.59 m) retracted; 11' (3.35 m) expanded width;
Accessories				
Cutting Edges	✓	✓	✓	✓
Rubber Deflector	✓	✓	✓	✓
Anti-Wear Shoes	✓	✓	✓	✓
Wing Extension Kit	–	✓	–	–
Scrape Maxx™ Kit	✓	✓	✓	✓
Back Drag Edge	–	✓	–	–

SNOWPLOW SPECIFICATIONS & ACCESSORIES

Snowplow	6800LT & 7200LT	7600RD & 8000RD	HD
Blade Widths	7'6" (2.29 m)	7'6" (2.29 m) 8' (2.44 m)	7'6" (2.29 m) 8' (2.44 m) 8'6" (2.59 m)
Accessories			
Cutting Edges	3/8" Steel 1/4" Steel 1" Poly	5/16" Steel 3/8" Steel 1/2" Steel	1/2" Steel
Rubber Deflector	✓	✓	✓
Curb Guards	✓	–	–
Anti-Wear Shoes	✓	✓	✓
Wing Extension Kit	–	–	✓
Back Drag Edges	–	✓	✓
Scrape Maxx™ Kit	✓	✓	✓

SNOWPLOW SPECIFICATIONS & ACCESSORIES

HYDRAULIC UNITS: PUMP MOTOR SPECIFICATIONS

BLADE	HDV™	LT Blades	RD Blades	POWER PLOW™	SPEEDWING™ & HD Blades
Hydraulic Unit Reservoir	2-1/2 qt (2.37 L)	1-3/4 qt (1.66 L)			
Hydraulic System Total	4-1/2 qt (4.26 L)	2-3/8 to 2-3/4 qt (2.25 L to 2.6 L)			
Pump Motor	12V DC with ± Connection				
Pump Relief Valve	2175–2325 psi	1750–1850 psi	1750–1850 psi	1950–2050 psi	1950–2050 psi
Angling Relief Valve		4000 psi	4000 psi	–	4000 psi
Plowing Relief Valve	4550–4650 psi	–	–	4000 psi	–
Back Dragging Relief Valve	3650–3750 psi	–	–	–	–
Wing Plowing Relief Valves		–	–	1700 psi	–
Motor Diameter	4.5" (11.4 cm)	3" (8 cm)	3" (8 cm)	4.5" (11.4 cm)	4.5" (11.4 cm)
Motor	1.5 kW	0.8 kW	0.8 kW	1.5 kW	1.5 kW
Pump (gal/rev)	0.000652	0.000208	0.000477	0.000652	0.000477
Hydraulic Hose	1/4 SAE 100R1 3/8 SAE 100R17	1/4 SAE 100R1 3/8 SAE 100R17	1/4 SAE 100R1	1/4 SAE 100R1 3/8 SAE 100R17	1/4 SAE 100R1 3/8 SAE 100R17
Raise	3 seconds	2 seconds	2 seconds	2 seconds	2 seconds
Angle Side-to-Side	2 seconds	4 seconds	4 seconds	2 seconds	4 seconds
Wing Extends	–	–	–	2 seconds	–
Wing Retracts	–	–	–	2 seconds	–
Both Wings Extend	–	–	–	4 seconds	–
Both Wings Retract	–	–	–	3 seconds	–



TrynEx International, LLC
531 Ajax Drive
Madison Heights, MI 48071-2429
www.snowexproducts.com

 A DIVISION OF DOUGLAS DYNAMICS, LLC



This product conforms to EU Machinery Directive 2006/42/EC and Directive 2011/65/EC (RoHS2).



This product conforms to UK Supply of Machinery (Safety) Regulations 2008 and 2012 (RoHS2).

Copyright © 2022 Douglas Dynamics, LLC. All rights reserved. This material may not be reproduced or copied, in whole or in part, in any printed, mechanical, electronic, film, or other distribution and storage media, without the written consent of TrynEx International, LLC. Authorization to photocopy items for internal or personal use by TrynEx International outlets or snowplow owner is granted.

TrynEx International reserves the right under its product improvement policy to change construction or design details and furnish equipment when so altered without reference to illustrations or specifications used. TrynEx International or the vehicle manufacturer may require or recommend optional equipment for snow removal. Do not exceed vehicle ratings with a snowplow. This product is manufactured under the following U.S. patents: 7,134,227; 7,400,058; 7,681,334; 9,200,418; 9,822,563; CAN patents: 2,466,195; and other patents pending. TrynEx International offers a limited warranty for all snowplows and accessories. See separately printed page for this important information. The following are registered (®) or unregistered (™) trademarks of Douglas Dynamics, LLC: Automatrix®, BUCKET BLADE™, HDV™, POWER GRIP™, POWER PLOW™, SECURITY GUARD™, SnowEx®, SPEEDWING™, STORM SEEKER™, WIDE PASS™.